



Accessories for MTS Criterion™ Systems

Address a full spectrum of standard and unique monotonic testing requirements

be certain.

Table of Contents

Force Transducers (Load Cells) pages 4-6

Force Transducers for Series 40 Electromechanical) Systems

- » S-Beam 4
- » Low-Profile Bending Beam 5
- » Low-Profile Shear Beam 6

Extensometers pages 7-15

Contacting Extensometers

- » Displacement Gages 7
- » Axial Extensometers 8
- » Axial High-Temperature Extensometers 9
- » Axial Enhanced Travel Extensometers 10
- » High Elongation Extensometer 10
- » Axial Immersible Extensometers 11
- » Axial Sub-miniature Extensometers 11
- » Diametral Extensometers 12
- » Cross Sectional Strain Extensometers 12
- » Biaxial Extensometers 13
 - Gage Length Extenders for 634.11/.12/.25 Axial Extensometers 13

Non-Contacting Extensometers

- » LX Laser Extensometer 14
- » MTS Fundamental™ Video Extensometer (FVX) 14
- » Advantage™ Video Extensometers (AVX) 15

Grips, Platens & Fixtures for Series 40 (Electromechanical) Systems pages 16-46

Tensile Grips for Series 40 (EM) Systems

- » MTS Fundamental Bollard Grips 16
- » MTS Fundamental Roller Grips 17
- » MTS Fundamental Vise Grips 18
- » MTS Fundamental Screw Grips 19
- » MTS Fundamental Scissors Grips 20
- » MTS Fundamental Wedge Grips 21
- » MTS Fundamental Nut/Bolt/Shoulder Grips 22
- » Bionix® Bollard Grips 22
- » Bionix Roller Grips 23
- » Bionix Scissors Grips 24
- » Bionix Vise Grips 25

- » Advantage Pneumatic Clamp Grips 26
- » Advantage Screw Grips 27
- » Advantage Wedge Grips 28
- » Model 647 Hydraulic Wedge Grips 29
 - MTS Fundamental Pneumatic Grip Supply/Controller 30
 - Advantage Pneumatic Grip Supply/Controller 30
 - Model 685 Hydraulic Grip Supplies/Controllers 31
 - Grip Faces for MTS Fundamental Screw Action Grips 31
 - Grip Faces for Advantage Pneumatic Grips 32-33
 - Grip Faces for Advantage Screw Grips 34
 - Wedges for MTS Fundamental Wedge Grips 35
 - Wedges for Advantage Pneumatic 10,000 Grips 36
 - Wedges for Advantage Wedge Grips 37
 - Wedges for Model 647 Hydraulic Wedge Grips 37
 - Inserts for MTS Fundamental Nut/Bolt/Shoulder Grips 38

Compression Platens for Series 40 (EM) Systems

- » MTS Fundamental Steel Compression Platens 39-40
- » MTS Fundamental Aluminum Compression Platens 41
- » Bionix Stainless Steel Compression Platens 42
- » 643 Compression Platens 43

Bend Fixtures for Series 40 (EM) Systems

- » MTS Fundamental 3-Point Bend Fixtures 44
- » MTS Fundamental 3 & 4-Point Bend Fixtures 45
 - Rollers for Model 642 Bend Fixtures 46
- » MTS Fundamental Universal Joint 46

Environmental Simulation Tools pages 47-51

Furnaces for Series 40 (EM) Systems

- Pull Rods for MTS Fundamental Furnaces 47
- Controllers for Model 653 Furnaces 48
- MTS Fundamental Furnaces 48

Environmental Chambers for Series 40 (EM) Systems

- Extension Rods for Advantage Environmental Chambers 50
- MTS Fundamental Environmental Chamber 50

Fluid Baths for Series 40 (EM) Systems

- Fluid Bath Options 51

Spares Kits 52

Force Transducers for Series 40 (Electromechanical) Systems

S-Beam

- » Measures axial loads using S-shaped design with a single embedded strain gage
- » Offers exceptional value and extreme simplicity for low-capacity testing with minimal side loads
- » Ideal for low-force tension and compression testing of plastics, rubber and paper
- » Designed for accuracy and linearity
- » Available in a range of force capacities (1 N to 5 kN)



LSB.100

Model	Type	Force Rating	Accuracy	Compatible Frames	TEDS ID	Overload Protection	Mounting Thread Size
LSB.100	S-beam	.001 kN	class 0.5 from 1 to 100%	C42.503	yes	800% of capacity	M6 x 1
LSB.500	S-beam	.005 kN	class 0.5 from 1 to 100%	C42.503	yes	800% of capacity	M6 x 1
LSB.11	S-beam	.01 kN	class 0.5 from 1 to 100%	C42.503	yes	800% of capacity	M6 x 1
LSB.251	S-beam	.025 kN	class 0.5 from 1 to 100%	C42.503	yes	800% of capacity	M6 x 1
LSB.501	S-beam	.05 kN	class 0.5 from 1 to 100%	C42.503	yes	800% of capacity	M6 x 1
LSB.102	S-beam	.1 kN	class 0.5 from 1 to 100%	C42.503	yes	800% of capacity	M6 x 1
LSB.252	S-beam	.25 kN	class 0.5 from 1 to 100%	C42.503	yes	800% of capacity	M6 x 1
LSB.502	S-beam	.5 kN	class 0.5 from 1 to 100%	C42.503	yes	420% of capacity	M6 x 1
LSB.103	S-beam	1 kN	class 0.5 from 1 to 100%	C42.503	yes	420% of capacity	M6 x 1
LSB.203	S-beam	2 kN	class 0.5 from 1 to 100%	C42.503	yes	420% of capacity	M6 x 1
LSB.503	S-beam	5 kN	class 0.5 from 1 to 100%	C42.503	yes	420% of capacity	M12 x 1.25

Force Transducers for Series 40 (Electromechanical) Systems

Low Profile Bending Beam

- » Measure moderate axial loads using a compact design with four embedded strain gages
- » Ideal for tension and compression testing of soft metals, plastics and reinforced plastics
- » Low profile maximizes available test space
- » Designed for high accuracy, stiffness, overturning moment, stability and linearity
- » Available in a range of force capacities (1 kN to 300 kN)



LPB.102

Model	Type	Force Rating	Accuracy	Compatible Frames	TEDS ID	Overload Protection	Mounting Thread Size
LPB.102	Low Profile Bending	.1 kN	class 0.5 from 1 to 100%	C43.104 C43.304 C43.504 C44.104 C44.304	Yes	150% of capacity	M6 X 1
LPB.252	Low Profile Bending	.25 kN	class 0.5 from 1 to 100%	C43.104 C43.304 C43.504 C44.104 C44.404	Yes	150% of capacity	M6 X 1
LPB.502	Low Profile Bending	.5 kN	class 0.5 from 1 to 100%	C43.104 C43.304 C43.504 C44.104 C44.304	Yes	150% of capacity	M6 X 1

Force Transducers for Series 40 (Electromechanical) Systems

Low Profile Shear Beam

- » Measure moderately high axial loads using a unique design of four embedded strain gages
- » Ideal for tension and compression testing of hard metals and composites
- » Low profile maximizes available test space
- » Designed for high accuracy, stiffness, overturning moment, stability and linearity
- » Available in a range of force capacities (1 kN to 300 kN)



Model	Type	Force Rating	Accuracy	Compatible Frames	TEDS ID	Overload Protection	Mounting Thread Size
LPS.103	Low Profile Shear Beam	1 kN	class 0.5 from 1 to 100%	C43.104 C43.304 C43.504 C44.104 C44.304 C45.504 C45.105	Yes	150% of capacity	M12 x 1.25
LPS.253	Low Profile Shear Beam	2.5 kN	class 0.5 from 1 to 100%	C43.104 C43.304 C43.504 C44.104 C44.304 C45.504 C45.105	Yes	150% of capacity	M12 x 1.25
LPS.503	Low Profile Shear Beam	5 kN	class 0.5 from 1 to 100%	C43.104 C43.304 C43.504 C44.104 C44.304 C45.504 C45.105	Yes	150% of capacity	M12 x 1.25
LPS.104	Low Profile Shear Beam	10 kN	class 0.5 from 1 to 100%	C43.104 C43.304 C43.504 C44.104 C44.304 C45.504 C45.105	Yes	150% of capacity	M12 x 1.25
LPS.204	Low Profile Shear Beam	20 kN	class 0.5 from 1 to 100%	C43.104 C43.304 C43.504 C44.104 C44.304 C45.504 C45.105	Yes	150% of capacity	M12 x 1.25
LPS.304	Low Profile Shear Beam	30 kN	class 0.5 from 1 to 100%	C43.104 C43.304 C43.504 C44.104 C44.304 C45.504 C45.105	Yes	150% of capacity	M12 x 1.25
LPS.504	Low Profile Shear Beam	50 kN	class 0.5 from 1 to 100%	C43.104 C43.304 C43.504 C45.504 C45.105 C45.305	Yes	150% of capacity	M27 x 2
LPS.105	Low Profile Shear Beam	100 kN	class 0.5 from 1 to 100%	C45.504 C45.105 C45.305	Yes	150% of capacity	M27 x 2
LPS.155	Low Profile Shear Beam	150 kN	class 0.5 from 1 to 100%	C45.305	Yes	150% of capacity	M27 x 2
LPS.205	Low Profile Shear Beam	200 kN	class 0.5 from 1 to 100%	C45.305	Yes	150% of capacity	M36 x 2
LPS.305	Low Profile Shear Beam	300 kN	class 0.5 from 1 to 100%	C45.305	Yes	150% of capacity	M36 x 2

Contacting Extensometers

Displacement Gage

- » Ideal for testing advanced materials and composites
- » Extremely versatile: designed for measuring small deformations, bend testing or specimens with unusual geometries
- » Measures displacement in contact with specimen or on an active component in the force train
- » Meets and/or exceeds ASTM E83 Class B1 and ISO 9513 Class 0.5 calibration requirements



Model	Type	Height	Length	Travel	Accuracy	Temperature Range
632.06H-20	Displacement Gage	101 mm	101 mm	-4 mm to 4 mm	class 0.5	-100° C to 150° C

Contacting Extensometers

Axial Extensometers

- » Provide reliable, repeatable means to accurately measure axial strain for testing metals, plastics, composites and ceramics with round or flat specimen geometries
- » Available in many gage lengths (10 to 50 mm) and travel ranges (± 1.5 to 50 mm)
- » Meet and/or exceed ASTM E83 Class B1 and ISO 9513 Class 0.5 calibration requirements
- » *See Gage Length Extenders for 634.11 / .12 / .25 Axial Extensometers...page 13*



Model	Type	Gage Length(s)	Travel	Accuracy	Temperature Range
632.13F-20	Axial	10 mm	+/- 1.5 mm	class 0.5	-100° C to 150° C
632.26E-30	Axial	0.3 in	+/- 0.018 in	class 0.5	-150° F to 350° F
632.26E-31	Axial	0.3 in	+/- 0.018 in	class 0.5	452° F to 150° F
632.26E-33	Axial	0.3 in	+/- 0.018 in	class 0.5	-150° F to 350° F
632.26E-40	Axial	0.5 in	+/- 0.045 in	class 0.5	-150° F to 300° F
632.26E-41	Axial	0.5 in	+/- 0.045 in	class 0.5	-452° F to 150° F
632.26E-43	Axial	0.5 in	+/- 0.045 in	class 0.5	-150° F to 350° F
632.26F-20	Axial	8 mm	+/- 1.2 mm	class 0.5	-100° C to 150° C
632.26F-21	Axial	8 mm	+/- 1.2 mm	class 0.5	-269° C to 65° C
632.26F-23	Axial	8 mm	+/- 1.2 mm	class 0.5	-100° C to 175° C
632.26F-30	Axial	8 mm	+/- 0.48 mm	class 0.5	-100° C to 150° C
632.26F-31	Axial	8 mm	+/- 0.48 mm	class 0.5	-269° C to 65° C
632.26F-33	Axial	8 mm	+/- 0.48 mm	class 0.5	-100° C to 175° C
632.26F-40	Axial	12 mm	+/- 1.08 mm	class 0.5	-100° C to 150° C
632.26F-41	Axial	12 mm	+/- 1.08 mm	class 0.5	-269° C to 65° C
632.26F-43	Axial	12 mm	+/- 1.08 mm	class 0.5	-100° C to 175° C
634.11F-24	Axial	25 mm	+/- 2.5 mm	class 0.5	-85° C to 120° C
634.11F-54	Axial	25 mm	5 mm	class 0.5	-85° C to 120° C
634.12F-24	Axial	25 mm	-2.5 mm to 12.5 mm	class 0.5	-85° C to 120° C
634.12F-54	Axial	25 mm	12.5 mm	class 0.5	-85° C to 120° C
634.25F-24	Axial	50 mm	-5 mm to 25 mm	class 0.5	-85° C to 120° C
634.25F-54	Axial	50 mm	25 mm	class 0.5	-85° C to 120° C
634.31F-24	Axial - Multiple Gage Length	10, 15, 20, 25, 30, 35, 40, 45, 50 mm	-2 mm to 4 mm	class 0.5	-85° C to 120° C

Contacting Extensometers

Axial High-Temperature Extensometers

- » Lightweight, low-contact-force devices for measuring strain in tests up to 2200° F (1200° C) in furnaces or induction heaters
- » Designed for high-temperature tension and compression testing applications, typically for round metal and ceramic specimens
- » Maximize accuracy in complex high-temperature materials tests that require precise measurement of thermal gradients
- » Meet and/or exceed ASTM E83 Class B1 and ISO 9513 Class 0.5 calibration requirements



Model	Type	Gage Length(s)	Travel	Accuracy	Temperature Range
632.53F-11	Axial High-Temperature	25 mm	-1.25 mm to 2.5 mm	class 0.5	Max: 1200° C
632.53F-14	Axial High-Temperature	12 mm	-1.2 mm to 2.4 mm	class 0.5	Max: 1200° C
632.54F-11	Axial High-Temperature	25 mm	-1.25 mm to 2.5 mm	class 0.5	Max: 1200° C
632.54F-14	Axial High-Temperature	12 mm	-1.2 mm to 2.4 mm	class 0.5	Max: 1200° C

Contacting Extensometers

Axial Enhanced Travel Extensometers

- » Available in 25 and 50 mm gage lengths to enable measurement over a longer travel range without compromising accuracy
- » Suited for tension testing with +100% strain capability, typically for flat or round metal and plastic specimens



Model	Type	Gage Length(s)	Travel	Accuracy	Temperature Range
632.24F-50	Axial – Enhanced Travel	25 mm	25 mm	class 1.0	-100° C to 150° C
634.28F-24	Axial – Enhanced Travel	50 mm	50 mm	class 0.5	-100° C to 150° C

High Elongation Extensometer

- » Designed to accurately measure strain in materials that are prone to very large displacement in tension, such as elastomers, semi-rigid plastics and films
- » Employs adjustable mechanical spring to measure strain over a wider range than is typical, up to 850 mm
- » Meets and/or exceeds ASTM E83 Class B1 and ISO 9513 Class 0.5 calibration requirements
- » The gripping force is applied using adjustable springs
- » High resolution optical digital encoder eliminates noise, signal drift, and output changes

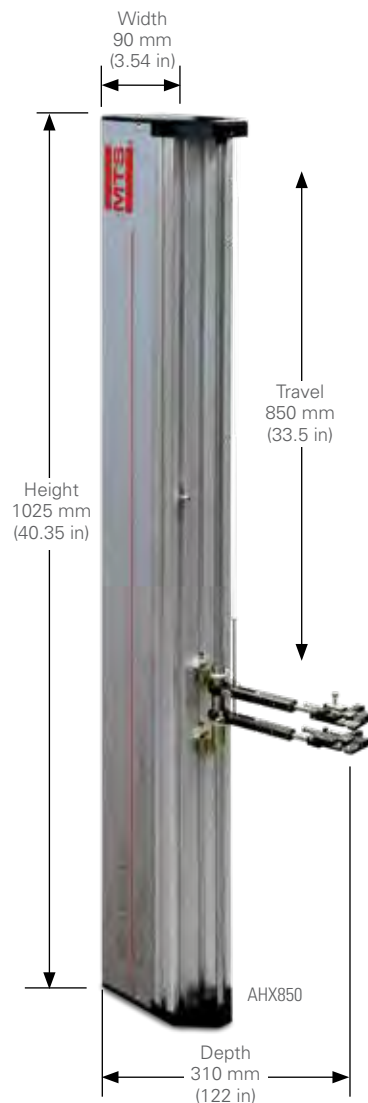

Model	Type	Preset Gage Length(s)	Travel	Accuracy	Resolution	Temperature Range
AHX850	Axial – high-elongation	10, 20, 25, 50, 75, 100 mm	850 mm	class 0.5	0.012 mm	5° C to 50° C

Contacting Extensometers

Axial Immersible Extensometer

- » Designed to accurately measure axial strain while completely submerged in water or saline solution
- » Ideal for tension testing of biomaterials
- » Patented parallel flexure system accurately translates specimen displacement to a hermetically sealed LVDT
- » Meet and/or exceed ASTM E83 Class B1 and ISO 9513 Class 0.5 calibration requirements

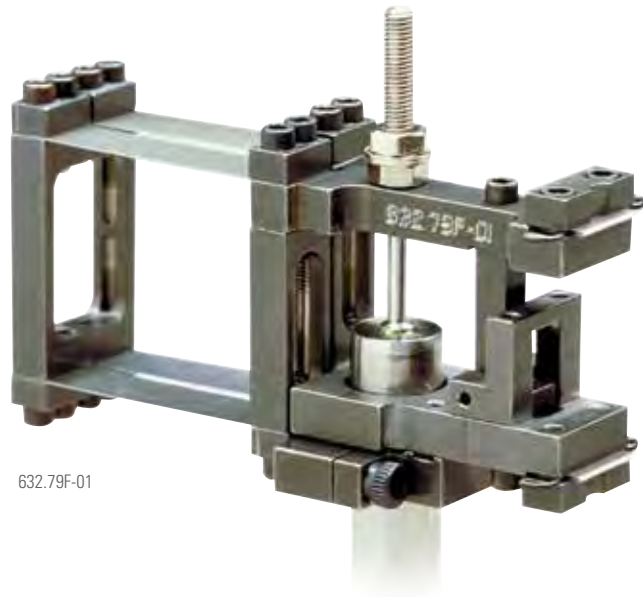

632.79F-01

Model	Type	Gage Length(s)	Travel	Accuracy	Temperature Range
632.79F-01	Axial Immersible	25 mm	+/- 6.25 mm	class 0.5	-15° C to 85° C

Axial Sub-miniature Extensometers

- » Designed for accurately measuring axial strain on specimens that require a smaller device, such as short or thin wires, delicate materials and small organics
- » Available in gage lengths of 3, 5 and 6 mm and travel ranges of ± 0.24 mm and 0.5 to 1.5 mm
- » Meet and/or exceed ASTM E83 Class B1 and ISO 9513 Class 0.5 calibration requirements



632.29F-20

Model	Type	Gage Length(s)	Travel	Accuracy	Temperature Range
632.29F-20	Axial Sub-miniature	3 mm	+/- 0.24 mm	class 0.5	-100° C to 150° C
632.29E-30	Axial Sub-miniature	6 mm	+/- 0.24 mm	class 0.5	-100° C to 150° C
632.29F-30	Axial Sub-miniature	5 mm	-0.5 mm to 1.5 mm	class 0.5	-100° C to 150° C

Contacting Extensometers

Diametral Extensometers

- » Ideal for tension and compression testing of round specimens, determining Poisson's ratio or measuring cross-sectional area change
- » Available in gage diameters of 6.1 to 26 mm
- » Models optimized for ambient temperature, cryogenic and elevated temperature testing
- » Meet and/or exceed ASTM E83 Class B1 and ISO 9513 Class 0.5 calibration requirements



632.18F-20

Model	Type	Gage Diameter	Travel	Accuracy	Temperature Range
632.18F-20	Diametral	6.1 mm to 26 mm	-2 mm to 2 mm	class 0.5	-100° C to 150° C
632.18F-21	Diametral	6.1 mm to 26 mm	-2 mm to 2 mm	class 0.5	-270° C to 65° C
632.18F-23	Diametral	6.1 mm to 26 mm	-2 mm to 2 mm	class 0.5	-100° C to 175° C

Cross Sectional Strain Extensometer

- » Dedicated, single-purpose extensometer for measuring cross-sectional strain
- » Can be paired with other axial extensometers to measure the “R” value of plastics and sheet metal
- » Unique design allows one-hand mounting
- » Free-floating feature enables it to travel with the specimen as it is elongated during axial loading
- » Meets and/or exceeds ASTM E83 Class B1 and ISO 9513 Class 0.5 calibration requirements



632.23F-30

Model	Type	Gage Width	Specimen Thickness	Travel	Accuracy	Temperature Range
632.23F-30	Cross Sectional Strain	20 mm	.5 mm to 5 mm	-4 mm	class 0.5	-100° C to 150° C

Contacting Extensometers

Biaxial Extensometer

- » Designed to accurately measure cross-sectional, diametral and average axial strain to help find Poisson's ratio
- » Ideal for tension and compression testing of plastic and composite specimens in many shapes and sizes
- » Minimizes mechanical crosstalk between axial and transverse channels
- » Meets and/or exceeds ASTM E83 Class B1 and ISO 9513 Class 0.5 calibration requirements



632.85F-05

Model	Type	Gage Length	Travel Axial	Travel Transverse	Accuracy	Temperature Range
632.85F-05	Biaxial	25 mm	1.2 mm to -1.5 mm	+/- .5 mm	class 0.5	-100° C to 150° C



634.11F-24
(with extender)

GAGE LENGTH EXTENDERS FOR 634.11 / .12 / .25 AXIAL EXTENSOMETERS

- » See Axial Extensometers...page 8

Model	Type	Compatible Extensomer(s)	Gage Dimension(s)
634.15C-31	Gage Length Extenders	634.11F, 634.12F	100 mm
634.15C-32	Gage Length Extenders	634.11F, 634.12F	150 mm
634.15C-33	Gage Length Extenders	634.11F, 634.12F	200 mm
634.15C-37	Gage Length Extender Kit	634.11F, 634.12F	50, 100, 150, 200 mm
634.15C-40	Gage Length Extenders	634.25 (C/F)	100 mm
634.15C-41	Gage Length Extenders	634.25 (C/F)	150 mm
634.15C-42	Gage Length Extenders	634.25 (C/F)	200 mm
634.15C-47	Gage Length Extender Kit	634.25 (C/F)	100, 150, 200 mm
634.15C-4X	Gage Length Extenders	634.25 (C/F)	80 mm

Non-Contacting Extensometers

LX Laser Extensometers

- » Utilize scanning laser and reflective targets to measure axial strain
- » Analog output port for closed loop strain control or input to a data acquisition board or chart recorder
- » Self-contained, easily portable, user-friendly design
- » Meet accuracy requirements as stated in ASTM E83 Class B1
- » Certified with the Center for Devices and Radiological Health as Class II products



LX 500

Model	Type	Travel	Accuracy	Voltage	Non-linearity	Repeatability	Resolution
LX 500	Laser	5 mm to 127 mm	class B1	110 V	0.009 mm	0.003 mm	0.001 mm
LX 500	Laser	5 mm to 127 mm	class B1	220 V	0.009 mm	0.003 mm	0.001 mm
LX 1500	Laser	8 mm to 381 mm	class B2	110 V	0.05 mm	0.05 mm	0.01 mm
LX 1500	Laser	8 mm to 381 mm	class B2	220 V	0.05 mm	0.05 mm	0.01 mm

Non-Contacting Extensometers

Measurement Head Specifications

Each AVX Measurement Head includes an inspected, traceable validation block, which can be used to confirm calibration at the beginning of a series of tests. Validation blocks are serialized and include an ISO 17025 Accreditation Calibration Report.

XT-100 Series Measurement Heads

Ideal for determining higher strain (>10%) materials properties such as yield point & elongation, and for long gage lengths. All models are capable of meeting Class B-2 (ASTM E-83) & Class 0.5 (ISO 9513) at the specified gage lengths and strain ranges (>10%). They are also capable of

meeting Class B-1 (ASTM E-83) over most of their operating range (gage lengths where maximum axial tensile strain less than 600%). The XT-100 series operate at measurement rates from 0.1 - 500 Hz.



AVX Measurement Head	Maximum Axial Tensile Strain Range (%) at Specified Gage Length (mm) ¹					Maximum Axial Compressive Strain Range (%) at Specified Gage Length (mm) ¹					Maximum Transverse Gage Length (mm) ²	Typical Extension Resolution (μm) ³	Minimum Specimen Width for Measurements (mm) ⁴		Maximum Tracking Speed (mm/min) ²	Field of View (mm)
	10	25	50	100	200	10	25	50	100	200			Axial	Transverse		
XT-101	280	70	-	-	-	40	40	-	-	-	10	0.3	1.5	4	1350	57 x 16
XT-102	530	170	50	-	-	40	40	40	-	-	19	0.4	2.4	7	2100	98 x 27
XT-103	840	300	120	25	-	40	40	40	-	-	29	0.6	3.4	10	3200	150 x 42
XT-104	1000	460	200	65	-	40	40	40	-	-	43	0.9	5	14	4600	220 x 62
XT-105	-	800	360	150	40	-	-	40	40	40	70	1.4	8	23	7200	350 x 100
XT-106	-	1000	500	220	70	-	-	40	40	40	65	1.8	11	30	9400	460 x 100
XT-107	-	-	800	360	150	-	-	-	40	40	-	2.8	16	-	14000	700 x 100

1. Strain ranges assume a distance between the grips of twice the GL, with a centrally positioned gage. Actual strain ranges may be greater or less than these values, depending on gage positioning, grip separation and specimen behavior.

2. Maximum transverse GL and tracking speed is quoted at a measurement rate of 100 Hz.

3. Resolution is based on typical lab performance.

4. For Class B-1, minimum specimen width for transverse gage lengths should be increased by 65%.

Note: Working distance is 480 mm.

XT-200 Series Measurement Heads

Ideal for determining low strain materials properties (from 0.01%), such as tensile & compressive modulus, Poisson's ratio & R-value. All models are capable of meeting Class B-1 (ASTM E-83) & Class 0.5 (ISO 9513) at the specified gage lengths and strain ranges.

The XT-200 series are our highest accuracy measurement heads. These models operate at measurement rates from 0.1 - 30 Hz. The XT-250 series are suitable for many high accuracy dynamic applications, and operate at measurement rates from 0.1 - 500 Hz.



AVX Measurement Head	Maximum Axial Tensile Strain Range (%) at Specified Gage Length (mm) ¹			Maximum Axial Compressive Strain Range (%) at Specified Gage Length (mm) ¹			Maximum Transverse Gage Length (mm) ²	Typical Extension Resolution (μm) ³	Minimum Specimen Width for Measurements (mm)		Maximum Tracking Speed (mm/min) ²	Field of View (mm)
	10	25	50	10	25	50			Axial	Transverse		
XT-204	300	80	10	40	40	25	45	0.18	1.0	4.6	250	61 x 51
XT-205	460	145	40	40	40	40	63	0.25	1.4	6.4	350	86 x 72
XT-254	390	120	25	40	40	40	15	0.3	1.7	8	1900	76 x 21
XT-255	580	190	65	40	40	40	21	0.4	2.4	11	2600	107 x 30

1. Specified strain ranges assume a distance between the grips of twice the GL, with a centrally positioned gage. Actual strain ranges may be greater or less than these values, depending on gage positioning, grip separation and specimen behavior.

2. Maximum transverse GL and tracking speed is quoted at a measurement rate of 15Hz (XT-20x series) and 100 Hz (XT-25x series).

3. Resolution based on typical lab performance.

Note: Working distance is 273 mm and is subject to +/- 5% tolerance.

Tensile Grips for Series 40 (EM) Systems

MTS Fundamental Bollard Grips

- » Value-priced grips designed to reduce stress concentration on specimens and avoid grip-induced failures
- » Suitable for tensile tests of cords, filaments, fibers, fine wire and yarn
- » Available in force ratings of 500 N, 2 kN and 10 kN
- » Available in horn style with pneumatic or manual clamping, or a capstan style with manual clamping
- » Anti-rotation features and integrated alignment pins enhance test accuracy and repeatability
- » See *MTS Fundamental Pneumatic Grip Supply/Controller...* page 30



FCB502B – Manual Horn



FCH203A – Manual Capstan



FCQA502A – Pneumatic Horn



FCA104B – Manual Bollard

Model	Type	Face	Force Capacity	Weight	Specimen Range	Compatible Frames	Temperature Rating	Air Pressure	Attachment Type	Grip/Height Width
FCB502B	Manual Horn	Rubber	0.5 kN	910 g	0-1.5 mm	C42.503 C43.104 C43.304 C43.504 C44.104 C44.304 C45.504 C45.105	0° C (32° F) to 50° C (122° F)	n/a	D	Height 152 mm (5.984 in) Width 114.4 mm (2.295 in)
FCH203A	Manual Capstan	Rubber	2 kN	1067 g	0-2 mm	C42.503 C43.104 C43.304 C43.504 C44.104 C44.304 C45.504 C45.105	0° C (32° F) to 50° C (122° F)	n/a	D	Height 143 mm (5.630 in) Width 177 mm (6.969 in)
FCQA502A	Pneumatic Horn	Smooth Steel	0.5 kN	1125 g	0-1.5 mm	C42.503 C43.104 C43.304 C43.504 C44.104 C44.304 C45.504 C45.105	0° C (32° F) to 50° C (122° F)	1 MPa (145 psi) See MTS Fundamental Pneumatic Grip Supply/ Controller	D	Height 147.5 mm (5.787 in) Width 154.5 mm (6.083 in)
FCA104B	Manual Bollard	Smooth Steel	10 kN	2200 g	0-1.5 mm	C43.104 C43.304 C43.504 C44.104 C44.304 C45.504 C45.105	0° C (32° F) to 50° C (122° F)	n/a	D	Height 200 mm (7.87 in) Width 141 mm (5.55 in)

Tensile Grips for Series 40 (EM) Systems

MTS Fundamental Roller Grips

- » Value-priced grips designed for quick loading and self-tightening
- » Suitable for tensile tests of bandages, textiles, synthetics and flexible polymers
- » Available in 100 kN force rating
- » Anti-rotation features and integrated alignment pins enhance test accuracy and repeatability



FCA105C

Model	Type	Force Capacity	Weight	Specimen Range	Compatible Frames	Temperature Rating	Attachment Type	Grip/Height Width
FCA105C	Roller	100 kN	7130 g	0-5 mm	C43.104 C43.304 C43.504 C44.104 C44.304 C45.504 C45.105	-50° C (-58° F) to 150° C (302° F)	D	242 mm/138 mm

Tensile Grips for Series 40 (EM) Systems

MTS Fundamental Vice Grips

- » Value-priced vice action grips for tensile testing of paper, plastic film, textiles, sheet materials and packaging components
- » Available in range of force ratings of (10 N to 5 kN) and sizes with manual and pneumatic clamping
- » Standard rubber faces are included with all grips
- » Anti-rotation features and integrated alignment pins enhance test accuracy and repeatability
- » *See MTS Fundamental Pneumatic Grip Supply/Controller...page 30*



FDQA103B – Pneumatic Vice



FDQA101B– Pneumatic Vice



FDSA102A - Manual Vice



FDSA502B - Manual Vice



FSDS503A - Manual Vice

Model	Type	Force Capacity	Weight	Specimen Range	Compatible Frames	Temperature Rating	Air Pressure	Attachment Type	Grip/Height Width
FDQA103B	Pneumatic Vice	1 kN	1257 g	0-8 mm	C42.503 C43.104 C43.304 C43.504 C44.104 C44.304 C45.504 C45.105	0° C (32° F) to 50° C (122° F)	1 MPa (145 psi) See MTS Fundamental Pneumatic Grip Supply/ Controller	D	Height 149.25 mm (5.876 in) Width 130 mm (5.118 in)
FDQA101B	Pneumatic Vice	10 N	175 g	0-0.2 mm	C42.503 C43.104 C43.304 C43.504 C44.104 C44.304 C45.504 C45.105	0° C (32° F) to 50° C (122° F)	0.4-0.7 MPa	D	Bottom Height 139 mm (5.47 in) Top Height 129 mm (5.08 in) (2.01 in) Width 51 mm (2.01 in)
FDSA102A	Manual Vice	100 N	310 g	0-1.5 mm	C42.503 C43.104 C43.304 C43.504 C44.104 C44.304 C45.504 C45.105	0° C (32° F) to 50° C (122° F)	n/a	D	Height 92.5 mm (3.642 in) Width 71.5 mm (2.815 in)
FDSA502B	Manual Vice	0.5 kN	998 g	0-6 mm	C42.503 C43.104 C43.304 C43.504 C44.104 C44.304 C45.504 C45.105	0° C (32° F) to 50° C (122° F)	n/a	D	Height 119.5 mm (4.705 in) Width 111 mm (4.37 in)
FSDS503A	Manual Vice	5 kN	2007 g	0-7 mm	C42.503 C43.104 C43.304 C43.504 C44.104 C44.304 C45.504 C45.105	0° C (32° F) to 50° C (122° F)	n/a	D	Height 129.5 mm (5.098 in) Width 120 mm (4.724 in)

Tensile Grips for Series 40 (EM) Systems

MTS Fundamental Screw Grips

- » Value-priced screw action grips that deliver higher clamping forces than vise grips for tensile testing of stronger, larger paper, plastic plate and film, textiles, sheet materials and packaging specimens
- » Available in steel and stainless steel with manual clamping
- » Standard rubber faces are included with all grips
- » Anti-rotation features and integrated alignment pins enhance test accuracy and repeatability
- » *See Grip Faces for MTS Fundamental Screw Action Grips... page 31*



FDSC503B - Manual Screw



FDSB503B - Manual Screw
(stainless steel)

Model	Type	Force Capacity	Weight	Specimen Range	Compatible Frames	Temperature Rating	Air Pressure	Attachment Type	Grip/Height Width	
FDSC503B	Manual Screw	5 kN	2360 g	0-16 mm	C42.503	0° C (32° F) to 50° C (122° F)	n/a	D	Height 132.5 mm (5.217 in)	
					C43.104					
					C43.304					
					C43.504					
					C44.104					
					C44.304					
C45.504	Width 52 mm (2.047 in)									
C45.105										
FDSB503B		Manual Screw – Stainless Steel	5 kN	2360 g	0-16 mm	C42.503	0° C (32° F) to 50° C (122° F)	n/a	D	Height 132.5 mm (5.217 in)
						C43.104				
						C43.304				
						C43.504				
	C44.104									
	C44.304									
C45.504	Width 168.8 mm (6.646 in)									
C45.105										

Tensile Grips for Series 40 (EM) Systems

MTS Fundamental Scissors Grips

- » Value-priced scissor action grips feature self-tightening, self-aligning clamps
- » Suitable for tensile testing of delicate flat, flexible specimens like foil, films, rubber and flexible polymers
- » Available in force ratings of 200 and 500 N
- » Standard diamond faces included with all grips
- » Anti-rotation features and integrated alignment pins enhance test accuracy and repeatability



FGD203A - Manual Scissors



FGD503A - Manual Scissors

Model	Type	Force Capacity	Weight	Specimen Range	Compatible Frames	Temperature Rating	Attachment Type	Grip/Height Width
FGD203A	Manual Scissors	2 kN	1016 g	0-12 mm	C42.503	0° C (32° F) to 50° C (122° F)	D	Height
					C43.104			134 mm
					C43.304			(5.276 in)
					C43.504			Width
					C44.104			138 mm
					C44.304			(5.433 in)
C45.504								
C45.105								
FGD503A	Manual Scissors	5 kN	1735 g	0-14 mm	C42.503	0° C (32° F) to 50° C (122° F)	D	Height
					C43.104			170 mm
					C43.304			(6.693 in)
					C43.504			Width
					C44.104			153 mm
					C44.304			(6.024 in)
C45.504								
C45.105								

Tensile Grips for Series 40 (EM) Systems

MTS Fundamental Wedge Grips

- » Value-priced wedge action grips for tensile testing of strong plastics, aluminum and steel
- » Accommodate both flat and vee wedge styles
- » Available in force ratings of 10, 30, 100 and 300 kN
- » Design minimizes compressive or buckling forces during specimen insertion
- » Anti-rotation features and integrated alignment pins enhance test accuracy and repeatability
- » *See Wedges for MTS Fundamental Wedge Grips...page 35*



FXSC104B – Manual Wedge



FXSA104B – Manual Wedge



FXSA304A – Manual Wedge



FXSA105A – Manual Wedge

Model	Type	Force Capacity	Weight	Specimen Range	Compatible Frames	Temperature Rating	Attachment Type	Grip/Height Width
FXSC104B	Manual Wedge	10 kN	7466 g	0-12 mm	C43.104 C43.304 C43.504 C44.104 C44.304 C45.504 C45.105	0° C (32° F) to 50° C (122° F)	D	Height 187 mm (7.362 in) Width 155 mm (6.102 in)
FXSA104B	Manual Wedge	10 kN	3100 g	See Wedges for MTS Fundamental Wedge Grips	C43.104 C43.304 C43.504 C44.104 C44.304 C45.504 C45.105	0° C (32° F) to 50° C (122° F)	D	Height 157 mm (6.18 in) Width 104 mm (4.09 in)
FXSA304A	Manual Wedge	30 kN	9189 g	See Wedges for MTS Fundamental Wedge Grips	C43.104 C43.304 C43.504 C44.104 C44.304 C45.504 C45.105	0° C (32° F) to 50° C (122° F)	D	Height 272 mm (10.705 in) Width 370 mm (14.567 in)
FXSA105A	Manual Wedge	100 kN	14786 g	See Wedges for MTS Fundamental Wedge Grips	C43.504 C45.504 C45.105	0° C (32° F) to 50° C (122° F)	D	Height 271.9 mm (10.705 in) Width 370 mm (14.567 in)
FXSA305A	Manual Wedge	300 kN	26000 g	See Wedges for MTS Fundamental Wedge Grips	C45.305	0° C (32° F) to 50° C (122° F)	E	Height 295 mm (11.6 in) Width 429 mm (16.9 in)

Tensile Grips for Series 40 (EM) Systems

MTS Fundamental Nut/Bolt/Shoulder Grips



FLA105B Nut/Bolt Grip

FTA105B Shoulder Grip

Model	Type	Force Capacity	Weight	Specimen Range	Compatible Frames	Temperature Rating	Attachment Type	Grip/Height Width
FLA105B	Nut and Bolt	100 kN	4.1kg (9 lb)	Chose appropriate insert	C43.104 C43.304 C43.504 C44.104 C44.304 C45.504 C45.105 C45.305	0° C (32° F) to 50° C (122° F)	D	142 mm (5.6 in)/ 134 mm (5.3 in)
FTA105B	Shoulder	100 kN	4.5kg (10 lb)	Chose appropriate insert	C43.104 C43.304 C43.504 C44.104 C44.304 C45.504 C45.105 C45.305	0° C (32° F) to 50° C (122° F)	D	146 mm (5.7 in)/ 146 mm (5.7 in)

Bionix Bollard Grips

- » Value-priced, stainless steel grips designed to reduce stress concentration on specimens and avoid grip-induced failures
- » Suitable for tensile tests of cords, filaments, fibers, fine wire and biomaterials in fluid bath environments
- » Available in 1 kN force rating
- » Available in manual horn style
- » Standard rubber faces are included with all grips
- » Anti-rotation features and integrated alignment pins enhance test accuracy and repeatability
- » *See Fluid Baths for Series 40 (EM) Systems...page 51*



EnviroBath Optional Grip.01

Model	Type	Force Capacity	Weight	Maximum Specimen Diameter	Compatible Frames	Temperature Rating	Attachment Type	Height (each from clevis center)
EnviroBath Optional Grip.01	Manual Horn	1 kN	1010 g	3 mm	C42.503 C43.104 C43.304 C43.504 C44.104 C44.304 C45.504 C45.105	- 130° C to 250° C	D	124 mm

Tensile Grips for Series 40 (EM) Systems

Bionix Roller Grips

- » Value-priced, stainless steel grips featuring quick loading, self-tightening rollers
- » Suitable for tensile tests of bandages, biotextiles, diapers, synthetics and flexible polymers in fluid bath environments
- » Available in 1, 2 and 5 kN force ratings
- » Anti-rotation features and integrated alignment pins enhance test accuracy and repeatability
- » *See Fluid Baths for Series 40 (EM) Systems...page 51*



EnviroBath Optional Grip.05



EnviroBath Optional Grip.06

Model	Type	Force Capacity	Weight	Maximum Specimen Thickness	Maximum Specimen Width	Compatible Frames	Temperature Rating	Attachment Type	Height (each from clevis center)
EnviroBath Optional Grip.05	Roller Action	1 kN	1300 g	3 mm	50 mm	C42.503	- 10° C to 50° C	D	123 mm
						C43.104			
						C43.304			
						C43.504			
						C44.104			
						C44.304			
						C45.504			
C45.105									
EnviroBath Optional Grip.06	Roller Action	2 kN	1425 g	4 mm	50 mm	C42.503	- 130° C to 250° C	D	111 mm
						C43.104			
						C43.304			
						C43.504			
						C44.104			
						C44.304			
						C45.504			
C45.105									
EnviroBath Optional Grip.07	Roller Action	5 kN	2260 g	7 mm	75 mm	C42.503	- 130° C to 250° C	D	121 mm
						C43.104			
						C43.304			
						C43.504			
						C44.104			
						C44.304			
						C45.504			
C45.105									

Tensile Grips for Series 40 (EM) Systems

Bionix Scissors Grips

- » Value-priced, stainless steel scissor action grips with self-tightening, self-aligning clamps
- » Suitable for tensile testing of delicate flat, flexible specimens like foil, films, rubber, flexible polymers and biomaterials in fluid bath environments
- » Available in force rating of 1 kN
- » Anti-rotation features and integrated alignment pins enhance test accuracy and repeatability
- » See *Fluid Baths for Series 40 (EM) Systems...page 51*



EnviroBath Optional Grip.08

Model	Type	Force Capacity	Weight	Maximum Specimen Diameter	Compatible Frames	Temperature Rating	Attachment Type	Height (each from clevis center)
EnviroBath Optional Grip.08	Scissors Action	1 kN	850 g	10 mm	C42.503	- 130° C to 250° C	D	160 mm
					C43.104			
					C43.304			
					C43.504			
					C44.104			
					C44.304			
					C45.504			
C45.105								

Tensile Grips for Series 40 (EM) Systems

Bionix Vice Grips

- » Value-priced, stainless steel vice action grips
- » Suitable for tensile testing of plastic film, textiles, sheet materials, packaging components and biomaterials in fluid bath environment
- » Available in range of force ratings (100 N, 2 kN, 5 kN) with manual clamping
- » Standard rubber faces are included with all grips
- » Anti-rotation features and integrated alignment pins enhance test accuracy and repeatability
- » *See Fluid Baths for Series 40 (EM) Systems...page 51*



EnviroBath Optional Grip.08



EnviroBath Optional Grip.10

Model	Type	Force Capacity	Weight	Maximum Specimen Thickness	Maximum Specimen Width	Compatible Frames	Temperature Rating	Attachment Type	Height (each from clevis center)
EnviroBath Optional Grip.09	Vise Action	.1 kN	560 g	2 mm	10 mm	C42.503 C43.104 C43.304 C43.504 C44.104 C44.304 C45.504 C45.105	- 10° C to 50° C	D	100 mm
EnviroBath Optional Grip.10	Vise Action	2 kN	1000 g	3.5 mm	63 mm	C42.503 C43.104 C43.304 C43.504 C44.104 C44.304 C45.504 C45.105	- 10° C to 50° C	D	95 mm
EnviroBath Optional Grip.11	Vise Action	5 kN	3100 g	10 mm	80 mm	C42.503 C43.104 C43.304 C43.504 C44.104 C44.304 C45.504 C45.105	- 10° C to 50° C	D	140 mm

Tensile Grips for Series 40 (EM) Systems

Advantage Pneumatic Clamp Grips

- » Versatile, high-performance pneumatic clamps for tensile testing of a wide array of specimen types:
 - low-breaking-strength specimens
 - thin sheets, films and tapes
 - elastomers, plastics, rigid and semi-rigid films and sheets
- » Available in range of force ratings of (10 N to 10 kN)
- » Dual-acting grip faces ensure correct specimen alignment and eliminate bending strains
- » *See Grip Faces for Advantage Pneumatic Grips...pages 32-33*
- » *See Wedges for Advantage Pneumatic 10,000 Grips...page 36*
- » *See Advantage Pneumatic Grip Supply/Controller...page 30*



Advantage Pneumatic 10



Advantage Pneumatic 100/200



Advantage Pneumatic 2000



Advantage Pneumatic 10,000

Model	Type	Force Capacity	Weight	Specimen Range	Compatible Frames	Temperature Rating	Air Pressure	Attachment Type	Grip/Height Width
Advantage Pneumatic 10	Pneumatic Clamp	.01 kN	0.27 kg (0.60 lb)	5.00 mm (0.20 in)	C42.503	- 40° C (-40° F) to 200° C (400° F)	5.5 bar (80 psi)	B	Height
					C43.104				145.80 mm
					C43.304				(5.74 in)
					C43.504				Width
					C44.104				71.63 mm
C44.304	(2.80 in)								
Advantage Pneumatic 100/200	Pneumatic Clamp	.2 kN	0.91 kg (2.0 lb)	10.0 mm (0.39 in)	C42.503	- 40° C (-40° F) to 200° C (400° F)	5.5 bar (80 psi)	C	Height
					C43.104				187.71 mm
					C43.304				(7.39 in)
					C43.504				Width
					C44.104				114 mm
C44.304	(4.50 in)								
Advantage Pneumatic 2000	Pneumatic Clamp	2 kN (450 lbf)	2.7 kg (6.0 lb)	12.0 mm (0.47 in)	C42.503	- 40° C (-40° F) to 200° C (400° F)	5.5 bar (80 psi)	D	Height
					C43.104				210.31 mm
					C43.304				(8.28 in)
					C43.504				Width
					C44.104				147.32 mm
C44.304	(5.80 in)								
Advantage Pneumatic 10000	Pneumatic Clamp	10 kN (2200 lbf)	6.8 kg (15 lb)	25.4 mm (1.00 in)	C42.503	- 40° C (-40° F) to 200° C (400° F)	5.5 bar (80 psi)	D	Height
					C43.104				210.31 mm
					C43.304				(6.59 in)
					C43.504				Width
					C44.104				200 mm
C44.304	(7.88 in)								
					C45.504				
					C45.105				

Tensile Grips for Series 40 (EM) Systems

Advantage Screw Grips

- » Versatile, high-performance screw action grips that provide high clamping forces for tensile testing of metals, plastics, polymers and wood
- » Available in range of force ratings of (10 N to 10 kN)
- » Dual-acting grip faces ensure correct specimen alignment and eliminate bending strains
- » *See Grip Faces for Advantage Screw Grips...page 34*



Model	Type	Force Capacity	Weight	Specimen Range	Compatible Frames	Temperature Rating	Attachment Type	Grip/Height Width
Advantage Screw Action 100	Manual Screw Clamp	.1 kN (22 lbf)	0.36 kg (0.8 lb)	12 mm (0.5 in)	C42.503	- 40° C (-40° F) to 200° C (400° F)	C	Height
					C43.104			122 mm (4.80 in)
					C43.304			Width
					C43.504			129.5 mm (5.10 in)
					C44.104			
C44.304								
Advantage Screw Action 2000	Manual Screw Clamp	2 kN (450 lbf)	0.95 kg (2.1 lb)	19 mm (1 in)	C42.503	- 40° C (-40° F) to 200° C (400° F)	D	Height
					C43.104			132.92 mm (5.23 in)
					C43.304			Width
					C43.504			164 mm (6.46 in)
					C44.104			
C44.304								
Advantage Screw Action 5000	Manual Screw Clamp	5 kN (1100 lbf)	2.1 kg (4.6 lb)	25 mm (0.75 in)	C42.503	- 40° C (-40° F) to 200° C (400° F)	D	Height
					C43.104			161.11 mm (6.34 in)
					C43.304			Width
					C43.504			210.6 mm (8.29 in)
					C44.104			
C44.304								
Advantage Screw Action 10000	Manual Screw Clamp	10 kN (2200 lbf)	4.9 kg (10 lb)	25 mm (1 in)	C42.503	- 40° C (-40° F) to 200° C (400° F)	D	Height
					C43.104			161.11 mm (6.34 in)
					C43.304			Width
					C43.504			210.6 mm (8.29 in)
					C44.104			
C44.304								
					C45.504			
					C45.105			

Tensile Grips for Series 40 (EM) Systems

Advantage Wedge Grips

- » Versatile, high-performance wedge action grips designed for tensile tests that require more clamping force than screw or pneumatic grips
- » Available in range of force ratings of (10, 30, 50, 100 kN)
- » Ideal for testing metals, composites, ceramics, plastics and wood/paper products
- » Available with interchangeable serrated wedges for round or flat specimens
- » Self-tightening during testing reduces slippage
- » See *Wedges for Advantage Wedge Grips...page 37*



Advantage Wedge

Model	Type	Force Capacity	Weight	Specimen Range	Compatible Frames	Temperature Rating	Attachment Type	Grip/Height Width
Advantage Wedge 10	Manual Wedge	10 kN (2.2 kip)	4.5 kg (10 lb)	See Wedges for Advantage Wedge Grips	C43.104	-130° C (-200° F) to 315° C (600° F)	D	Height
					C43.304			201.17 mm (7.92 in)
					C43.504			Width
					C44.104			132.5 mm (5.22 in)
					C44.304			
					C44.504			
					C45.105			
Advantage Wedge 30	Manual Wedge	30 kN (6.7 kip)	5.5 kg (12 lb)	See Wedges for Advantage Wedge Grips	C43.104	-130° C (-200° F) to 315° C (600° F)	D	Height
					C43.304			231.39 mm (9.11 in)
					C43.504			Width
					C44.104			115 mm (4.50 in)
					C44.304			
					C45.504			
					C45.105			
Advantage Wedge 50	Manual Wedge	50 kN (11 kip)	7.0 kg (15 lb)	See Wedges for Advantage Wedge Grips	C43.104	-130° C (-200° F) to 315° C (600° F)	D	Height
					C43.304			235.97 mm (9.29 in)
					C43.504			Width
					C44.104			147.6 mm (5.81 in)
					C44.304			
					C44.504			
					C45.105			
Advantage Wedge 100	Manual Wedge	100 kN (22 kip)	15 kg (33 lb)	See Wedges for Advantage Wedge Grips	C45.504	-130° C (-200° F) to 315° C (600° F)	D	Height
					C45.105			269.24 mm (10.60 in)
								Width
								191.52 mm (7.54 in)
Advantage Wedge 150	Manual Wedge	150 kN	18.1 kg (40 lb)	Choose appropriate wedge	C43.104	-130° C (-200° F) to 315° C (600° F)	D	Height
					C43.304			285.2 mm (11.23 in)
					C43.504			Width
					C44.104			259.4 mm (10.22 in)
					C44.304			
					C45.504			
					C45.105			
					C45.305			
Advantage Wedge 300	Manual Wedge	300 kN	53.5 kg (118 lb)	Choose appropriate wedge	C43.104	-130° C (-200° F) to 315° C (600° F)	M36x2 Thread	Height
					C43.304			332 mm (13.1 in)
					C43.504			Width
					C44.104			407 mm (16.0 in)
					C44.304			
					C45.504			
					C45.105			
					C45.305			

Tensile Grips for Series 40 (EM) Systems

Model 647 Hydraulic Wedge Grips

- » Precision side-loading hydraulic wedge grips combine easy specimen insertion with highly accurate, repeatable loading
- » Available in force ratings of 30 kN, 100 kN and 300 kN
- » Ideal for tensile tests of metals, ceramics, composites, plastics and wood/paper products
- » Adjustable pressure allows grips to be used for testing a wide range of materials
- » A variety of wedge surfaces are available to meet any requirement
- » *See Wedges for Model 647 Hydraulic Wedge Grips...page 37*
- » *See Model 685 Hydraulic Grip Supplies/Controllers...page 31*



Model 647.02B

Model	Type	Force Capacity	Weight	Specimen Range	Compatible Frames	Temperature Rating	Hydraulic Power	Attachment Type	Grip/Height Width
647.02B	Side-loading Hydraulic Wedge	30 kN	7.30 kg (16.00 lb)	See Wedges for Model 647 Hydraulic Wedge Grips	C43.104	-40° to 177° C (-40° to 350° F)	See Model 685 Hydraulic Grip Supplies/Controllers	D	Height
					C43.304				173.30 mm (6.82 in)
					C43.404				Width
					C44.104				150.88 mm (5.94 in)
					C45.504				
C45.105									
647.10A	Side-loading Hydraulic Wedge	100 kN	27.00 kg (60.00 lb)	See Wedges for Model 647 Hydraulic Wedge Grips	C45.504	-40° to 177° C (-40° to 350° F)	See Model 685 Hydraulic Grip Supplies/Controllers	D	Height
					C45.105				217.88 mm (8.58 in)
									Width
									203.2 mm (8.00 in)
647.25A	Side-loading Hydraulic Wedge	300 kN	62.60 kg (138 lb)	See Wedges for Model 647 Hydraulic Wedge Grips	C45.504	-40° to 177° C (-40° to 350° F)	See Model 685 Hydraulic Grip Supplies/Controllers	1 1/2-12 UNF and M36 x 2 mm	Height
					C45.105				224.8 mm (8.85 in)
					C45.305				Width
									266.7 mm (10.50 in)

Tensile Grips for Series 40 (EM) Systems

MTS FUNDAMENTAL PNEUMATIC GRIP SUPPLY/CONTROLLER

- » Required for proper operation of MTS Fundamental Pneumatic Bollard and Vise Grips
- » Provides precise control of open/close functions, air pressure regulation and flow
- » See *MTS Fundamental Bollard Grips...page 16*
- » See *MTS Fundamental Vise Grips...page 18*



FPC2850

Model	Compatible Grip(s)	Output Pressure	Hose Diameter	Power Rating	Electrical Requirements
FPC2850	MTS Fundamental Pneumatic Grips: FCQA502A, FDQA103B	6.9 BAR (100 psi)	6 mm	5.5 W	12V DC

ADVANTAGE PNEUMATIC GRIP SUPPLY/CONTROLLER

- » Required for proper operation of Advantage Pneumatic Grips.
- » Provides precise control of open/close functions, air pressure regulation and flow
- » Magnetic-mount handset or optional footswitch that makes specimen loading hassle-free
- » See *Advantage Pneumatic Clamp Grips...page 26*



APG Controller



Optional Footswitch

Model	Compatible Grip(s)	Output Pressure	Hose Diameter	Power Rating	Electrical Requirements
APG Controller	Advantage Pneumatic 10, 100/200, 2000, 10,000	6.2 BAR (90 psi)	4 mm	2.5 W	120-240V AC
APG Controller Optional Footswitch	Advantage Pneumatic 10, 100/200, 2000, 10,000	—	—	—	—

Tensile Grips for Series 40 (EM) Systems

MODEL 685 HYDRAULIC GRIP SUPPLIES/CONTROLLERS

- » Required for proper operation of Model 647 Hydraulic Wedge Grips
- » Provide precise upper and lower grip clamp/release control, pressure control and rate adjustment
- » Enable tight control of highly uniform and consistent clamping forces
- » Intuitive, easy-to-use control interface facilitate streamlined test setup
- » Special hydraulic fluid allows the grips to be used in environmental chambers at elevated temperatures
- » Self-contained design allows for the use of hydraulic grips on non-hydraulic test systems
- » *See Model 647 Hydraulic Wedge Grips...page 29*



685.22D-05

Model	Compatible Grip(s)	Output Pressure	Hose Diameter	Power Rating	Electrical Requirements	Temperature Range	Dimensions (H x W x D)	Weight
685.22D-05	647.02B 647.10A	0.7 - 20.7 MPa (100 to 3000 psi)	.25 in	0.75 kW	115 V, 60 Hz	-40 to +177° C (-40 to +350° F)	91.44 x 44.45 x 43.18 cm	76 kg (170 lb)
685.22D-06	647.02B 647.10A	0.7 - 21 MPa (100 to 3000 psi)	.25 in	0.75 kW	100-115 V, 50 Hz	-40 to +177° C (-40 to +350° F)	91.44 x 44.45 x 43.18 cm	76 kg (170 lb)
685.22D-07	647.02B 647.10A	0.7 - 21 MPa (100 to 3000 psi)	.25 in	0.75 kW	208-230 V, 60 Hz	-40 to +177° C (-40 to +350° F)	91.44 x 44.45 x 43.18 cm	76 kg (170 lb)
685.22D-08	647.02B 647.10A	0.7 - 21 MPa (100 to 3000 psi)	.25 in	0.75 kW	200-240 V, 50 Hz	-40 to +177° C (-40 to +350° F)	91.44 x 44.45 x 43.18 cm	76 kg (170 lb)
685.10E-05	647.25A	10 to 70 MPa (1500 to 10000 psi)	.25 in	0.75 kW	115 V, 60 Hz	-40° C (-40° F) to 177° C (350° F)	91.44 x 44.45 x 43.18 cm	76 kg (170 lb)
685.10E-06	647.25A	10 to 70 MPa (1500 to 10000 psi)	.25 in	0.75 kW	100-115 V, 50 Hz	-40° C (-40° F) to 177° C (350° F)	91.44 x 44.45 x 43.18 cm	76 kg (170 lb)
685.10E-07	647.25A	10 to 70 MPa (1500 to 10000 psi)	.25 in	0.75 kW	208-230 V, 60 Hz	-40° C (-40° F) to 177° C (350° F)	91.44 x 44.45 x 43.18 cm	76 kg (170 lb)
685.10E-08	647.25A	10 to 70 MPa (1500 to 10000 psi)	.25 in	0.75 kW	200-240 V, 50 Hz	-40° C (-40° F) to 177° C (350° F)	91.44 x 44.45 x 43.18 cm	76 kg (170 lb)

GRIP FACES FOR MTS FUNDAMENTAL SCREW ACTION GRIPS

- » *See MTS Fundamental Screw Grips...page 19*

Model	Type	Compatible Grip(s)	Profile	Dimensions	Temperature Range	Specimen Range	Force Capacity
FDSC503B.01	Flat Face	FDSC503B	Serrated	35 mm x 35 mm	0° C (32° F) to 50° C (122° F)	0-16 mm	5 kN
FDSC503B.02	Flat Face	FDSC503B	Rubber	35 mm x 35 mm	0° C (32° F) to 50° C (122° F)	0-16 mm	5 kN

Tensile Grips for Series 40 (EM) Systems

GRIP FACES FOR ADVANTAGE PNEUMATIC GRIPS

» See *Advantage Pneumatic Clamp Grips...* page 26

Model	Type	Compatible Grip(s)	Profile	Dimensions	Temperature Range	Specimen Range	Force Capacity
APG101.01	Flat Face	Advantage Pneumatic 10	Smooth Steel	15 mm x 8 mm	-40° C (-40° F) to 200° C (400° F)	0-5 mm	.01 kN
APG101.02	Flat Face	Advantage Pneumatic 10	Serrated Steel	15 mm x 8 mm	-40° C (-40° F) to 200° C (400° F)	0- 5 mm	.01 kN
APG101.03	Flat Face	Advantage Pneumatic 10	Smooth Rubber	15 mm x 8 mm	0° C (32° F) to 50° C (122° F)	0- 5 mm	.01 kN
APG203.06	Flat Face	Advantage Pneumatic 100/200, 2000	Corrugated Rubber	25 mm x 25 mm	0° C (32° F) to 50° C (122° F)	0-10 mm, 0-12 mm	.2 kN, 2 kN
APG203.07	Flat Face	Advantage Pneumatic 100/200, 2000	Smooth Rubber	25 mm x 25 mm	0° C (32° F) to 50° C (122° F)	0-10 mm, 0-12 mm	.2 kN, 2 kN
APG203.08	Flat Face	Advantage Pneumatic 100/200, 2000	Steel Line Contact	25 mm x 25 mm	-40° C (-40° F) to 200° C (400° F)	0-10 mm, 0-12 mm	.2 kN, 2 kN
APG203.09	Flat Face	Advantage Pneumatic 100/200, 2000	Smooth Steel	70 mm x 25 mm	-40° C (-40° F) to 200° C (400° F)	0-10 mm, 0-12 mm	.2 kN, 2 kN
APG203.10	Flat Face	Advantage Pneumatic 100/200, 2000	Corrugated Steel	70 mm x 25 mm	-40° C (-40° F) to 200° C (400° F)	0-10 mm, 0-12 mm	.2 kN, 2 kN
APG203.11	Flat Face	Advantage Pneumatic 100/200, 2000	Serrated Steel	70 mm x 25 mm	-40° C (-40° F) to 200° C (400° F)	0-10 mm, 0-12 mm	.2 kN, 2 kN
APG203.12	Flat Face	Advantage Pneumatic 100/200, 2000	Saw-tooth Steel	70 mm x 25 mm	-40° C (-40° F) to 200° C (400° F)	0-10 mm, 0-12 mm	.2 kN, 2 kN
APG203.13	Flat Face	Advantage Pneumatic 100/200, 2000	Matte Rubber	70 mm x 25 mm	0° C (32° F) to 50° C (122° F)	0-10 mm, 0-12 mm	.2 kN, 2 kN
APG203.14	Flat Face	Advantage Pneumatic 100/200, 2000	Corrugated Rubber	70 mm x 25 mm	0° C (32° F) to 50° C (122° F)	0-10 mm, 0-12 mm	.2 kN, 2 kN
APG203.15	Flat Face	Advantage Pneumatic 100/200, 2000	Smooth Rubber	70 mm x 25 mm	0° C (32° F) to 50° C (122° F)	0-10 mm, 0-12 mm	.2 kN, 2 kN
APG203.16	Flat Face	Advantage Pneumatic 100/200, 2000	Smooth Steel	58 mm x 38 mm	-40° C (-40° F) to 200° C (400° F)	0-10 mm, 0-12 mm	.2 kN, 2 kN
APG203.17	Flat Face	Advantage Pneumatic 100/200, 2000	Corrugated Steel	58 mm x 38 mm	-40° C (-40° F) to 200° C (400° F)	0-10 mm, 0-12 mm	.2 kN, 2 kN
APG203.18	Flat Face	Advantage Pneumatic 100/200, 2000	Serrated Steel	58 mm x 38 mm	-40° C (-40° F) to 200° C (400° F)	0-10 mm, 0-12 mm	.2 kN, 2 kN

continued next page...

Tensile Grips for Series 40 (EM) Systems

GRIP FACES FOR ADVANTAGE PNEUMATIC GRIPS...continued

Model	Type	Compatible Grip(s)	Profile	Dimensions	Temperature Range	Specimen Range	Force Capacity
APG203.19	Flat Face	Advantage Pneumatic 100/200, 2000	Saw-tooth Steel	58 mm x 38 mm	-40° C (-40° F) to 200° C (400° F)	0-10 mm, 0-12 mm	.2 kN, 2 kN
APG203.20	Flat Face	Advantage Pneumatic 100/200, 2000	Matte Rubber	58 mm x 38 mm	0° C (32° F) to 50° C (122° F)	0-10 mm, 0-12 mm	.2 kN, 2 kN
APG203.21	Flat Face	Advantage Pneumatic 100/200, 2000	Corrugated Rubber	58 mm x 38 mm	0° C (32° F) to 50° C (122° F)	0-10 mm, 0-12 mm	.2 kN, 2 kN
APG203.22	Flat Face	Advantage Pneumatic 100/200, 2000	Smooth Rubber	58 mm x 38 mm	0° C (32° F) to 50° C (122° F)	0-10 mm, 0-12 mm	.2 kN, 2 kN
APG203.23	Flat Face	Advantage Pneumatic 100/200, 2000	Steel Line Contact (R=4.75 mm)	58 mm x 38 mm	0° C (32° F) to 50° C (122° F)	0-10 mm, 0-12 mm	.2 kN, 2 kN
APG203.24	Flat Face	Advantage Pneumatic 100/200, 2000	Grab Test	58 mm x 38 mm	0° C (32° F) to 50° C (122° F)	0-10 mm, 0-12 mm	.2 kN, 2 kN
APG203.25	Flat Face	Advantage Pneumatic 100/200, 2000	Smooth Rubber	25 mm x 25 mm	0° C (32° F) to 50° C (122° F)	0-10 mm, 0-12 mm	.2 kN, 2 kN
APG203.26	Flat Face	Advantage Pneumatic 100/200, 2000	Line Contact Rubber Opposite (R=4.75 mm)	25 mm x 12.5 mm	0° C (32° F) to 50° C (122° F)	0-10 mm, 0-12 mm	.2 kN, 2 kN
APG203.27	Flat Face	Advantage Pneumatic 100/200, 2000	Line Contact Rubber Opposite (R=4.75 mm)	58 mm x 38 mm	0° C (32° F) to 50° C (122° F)	0-10 mm, 0-12 mm	.2 kN, 2 kN
APG203.28	Flat Face	Advantage Pneumatic 100/200, 2000	Saw-tooth Steel	150 mm x 25 mm	-40° C (-40° F) to 200° C (400° F)	0-10 mm, 0-12 mm	.2 kN, 2 kN
APG203.29	Flat Face	Advantage Pneumatic 100/200, 2000	Line Contact Rubber Opposite (R=2.5 mm)	25 mm x 25 mm	0° C (32° F) to 50° C (122° F)	0-10 mm, 0-12 mm	.2 kN, 2 kN
APG203.30	Flat Face	Advantage Pneumatic 100/200, 2000	Smooth Rubber	150 mm x 25 mm	0° C (32° F) to 50° C (122° F)	0-10 mm, 0-12 mm	.2 kN, 2 kN

Tensile Grips for Series 40 (EM) Systems

GRIP FACES FOR ADVANTAGE SCREW GRIPS

» See *Advantage Screw Grips...* page 27

Model	Type	Compatible Grip(s)	Profile	Dimensions	Temperature Range	Specimen Range	Force Capacity
ASG104.01	Flat Face	Advantage Screw Action 5000, 10000	Corrugated Steel	50 mm x 75 mm	-40° C (-40° F) to 200° C (400° F)	0 to 25 mm	5 kN, 10 kN
ASG104.02	Flat Face	Advantage Screw Action 5000, 10000	Serrated Steel	50 mm x 75 mm	-40° C (-40° F) to 200° C (400° F)	0 to 25 mm	5 kN, 10 kN
ASG104.03	Flat Face	Advantage Screw Action 5000, 10000	Saw-tooth Steel	50 mm x 75 mm	-40° C (-40° F) to 200° C (400° F)	0 to 25 mm	5 kN, 10 kN
ASG104.04	Flat Face	Advantage Screw Action 5000, 10000	Matte Rubber	50 mm x 75 mm	6° C (32° F) to 50° C (122° F)	0 to 25 mm	5 kN, 10 kN
ASG104.05	Flat Face	Advantage Screw Action 5000, 10000	Corrugated Rubber	50 mm x 75 mm	6° C (32° F) to 50° C (122° F)	0 to 25 mm	5 kN, 10 kN
ASG104.06	Flat Face	Advantage Screw Action 5000, 10000	Smooth Rubber	50 mm x 75 mm	6° C (32° F) to 50° C (122° F)	0 to 25 mm	5 kN, 10 kN
ASG104.07	Flat Face	Advantage Screw Action 5000, 10000	Steel Line Contact (R=4.75 mm)	50 mm x 75 mm	-40° C (-40° F) to 200° C (400° F)	0 to 25 mm	5 kN, 10 kN
ASG104.08	Flat Face	Advantage Screw Action 5000, 10000	Grab Test	50 mm x 75 mm	-40° C (-40° F) to 200° C (400° F)	0 to 25 mm	5 kN, 10 kN
ASG104.09	Flat Face	Advantage Screw Action 5000, 10000	Line Contact Rubber Opposite (R=4.75 mm)	50 mm x 75 mm	6° C (32° F) to 50° C (122° F)	0 to 25 mm	5 kN, 10 kN

Tensile Grips for Series 40 (EM) Systems

WEDGES FOR MTS FUNDAMENTAL WEDGE GRIPS

» See MTS Fundamental Wedge Grips...page 21

Model	Type	Compatible Grip(s)	Profile	Dimensions	Temperature Range	Specimen Range	Force Capacity
FXSA105A.01	Flat Wedge	FXSA105A, FXSA304A	Flat	40 mm x 55 mm	0° C (32° F) to 50° C (122° F)	0-7 mm	100 kN
FXSA105A.02	Flat Wedge	FXSA105A, FXSA304A	Flat	40 mm x 55 mm	0° C (32° F) to 50° C (122° F)	7-14 mm	100 kN
FXSA105A.03	Flat Wedge	FXSA105A, FXSA304A	Flat	40 mm x 55 mm	0° C (32° F) to 50° C (122° F)	14-21 mm	100 kN
FXSA105A.04	Vee Wedge	FXSA105A, FXSA304A	Vee	40 mm x 55 mm	0° C (32° F) to 50° C (122° F)	ø4-ø9 mm	100 kN
FXSA105A.05	Vee Wedge	FXSA105A, FXSA304A	Vee	40 mm x 55 mm	0° C (32° F) to 50° C (122° F)	ø9-ø14 mm	100 kN
FXSA105A.06	Vee Wedge	FXSA105A, FXSA304A	Vee	40 mm x 55 mm	0° C (32° F) to 50° C (122° F)	ø14-ø19 mm	100 kN
FXSA305A.01 x 2	Flat	FXSA305A	Flat face	50 mm x 62 mm	0° C (32° F) to 50° C (122° F)	0-8 mm	300 kN
FXSA305A.02 x 2	Flat	FXSA305A	Flat face	50 mm x 62 mm	0° C (32° F) to 50° C (122° F)	8-16 mm	300 kN
FXSA305A.03 x 2	Flat	FXSA305A	Flat face	50 mm x 62 mm	0° C (32° F) to 50° C (122° F)	16-24 mm	300 kN
FXSA305A.04 x 2	Flat	FXSA305A	Flat face	50 mm x 62 mm	0° C (32° F) to 50° C (122° F)	24-32 mm	300 kN
FXSA305A.05 x 2	Round	FXSA305A	Vee face	50 mm x 62 mm	0° C (32° F) to 50° C (122° F)	ø4-ø9 mm	300 kN
FXSA305A.06 x 2	Round	FXSA305A	Vee face	50 mm x 62 mm	0° C (32° F) to 50° C (122° F)	ø9-ø16 mm	300 kN
FXSA305A.07 x 2	Round	FXSA305A	Vee face	50 mm x 62 mm	0° C (32° F) to 50° C (122° F)	ø16-ø23 mm	300 kN
FXSA305A.08 x 2	Round	FXSA305A	Vee face	50 mm x 62 mm	0° C (32° F) to 50° C (122° F)	ø23-ø30 mm	300 kN
FXSA104B.01 x 2	Flat	FXSA104B	Flat face	35 mm x 40 mm	0° C (32° F) to 50° C (122° F)	0-7 mm	10 kN
FXSA104B.02 x 2	Flat	FXSA104B	Flat face	35 mm x 40 mm	0° C (32° F) to 50° C (122° F)	7-13 mm	10 kN
FXSA104B.03 x 2	Round	FXSA104B	Vee face	35 mm x 40 mm	0° C (32° F) to 50° C (122° F)	ø4-ø9 mm	10 kN
FXSA104B.04 x 2	Round	FXSA104B	Vee face	35 mm x 40 mm	0° C (32° F) to 50° C (122° F)	ø9-ø14 mm	10 kN

Tensile Grips for Series 40 (EM) Systems

WEDGES FOR ADVANTAGE PNEUMATIC 10,000 GRIPS

» See Advantage Pneumatic Clamp Grips...page 26

Model	Type	Compatible Grip(s)	Profile	Dimensions	Temperature Range	Specimen Range	Force Capacity
APG104.01	Flat Wedge	Advantage Pneumatic 10,000	Saw-tooth Steel	25 mm x 38 mm	-40° C (-40° F) to 200° C (400° F)	18.8-25.9 mm	10 kN
APG104.02	Flat Wedge	Advantage Pneumatic 10,000	Saw-tooth Steel	25 mm x 38 mm	-40° C (-40° F) to 200° C (400° F)	0- 7.1 mm	10 kN
APG104.03	Flat Wedge	Advantage Pneumatic 10,000	Saw-tooth Steel	25 mm x 38 mm	-40° C (-40° F) to 200° C (400° F)	7.2 - 14.4 mm	10 kN
APG104.04	Vee Wedge	Advantage Pneumatic 10,000	Serrated Steel	25 mm x 38 mm	-40° C (-40° F) to 200° C (400° F)	3 - 8.1/9.4 mm	10 kN
APG104.05	Vee Wedge	Advantage Pneumatic 10,000	Serrated Steel	25 mm x 38 mm	-40° C (-40° F) to 200° C (400° F)	8.9 - 10.9/15.2 mm	10 kN
APG104.06	Vee Wedge	Advantage Pneumatic 10,000	Serrated Steel	25 mm x 38 mm	-40° C (-40° F) to 200° C (400° F)	14 - 18/20.8 mm	10 kN
APG104.07	Vee Wedge	Advantage Pneumatic 10,000	Serrated Steel	25 mm x 38 mm	-40° C (-40° F) to 200° C (400° F)	20.1 - 22.9/ 27.2 mm	10 kN
APG104.08	Round Wedge	Advantage Pneumatic 10,000	Surfallooy Steel	25 mm x 38 mm	-40° C (-40° F) to 200° C (400° F)	15 mm	10 kN
APG104.09	Round Wedge	Advantage Pneumatic 10,000	Saw-tooth Steel	25 mm x 38 mm	-40° C (-40° F) to 200° C (400° F)	12.7 mm	10 kN
APG104.10	Flat Wedge	Advantage Pneumatic 10,000	Surfallooy Steel	25 mm x 38 mm	-40° C (-40° F) to 200° C (400° F)	0 - 7.1 mm	10 kN
APG104.11	Flat Wedge –water cooled	Advantage Pneumatic 10,000	Saw-tooth Steel	25 mm x 38 mm	-40° C (-40° F) to 200° C (400° F)	0 - 7.1 mm	10 kN
APG104.12	Flat Wedge –water cooled	Advantage Pneumatic 10,000	Surfallooy Steel	25 mm x 38 mm	-40° C (-40° F) to 200° C (400° F)	0 - 7.1 mm	10 kN
APG104.13	Flat Wedge	Advantage Pneumatic 10,000	Saw-tooth Steel	50 mm x 38 mm	-40° C (-40° F) to 200° C (400° F)	0 - 7.1 mm	10 kN

Tensile Grips for Series 40 (EM) Systems

WEDGES FOR ADVANTAGE WEDGE GRIPS

» See Advantage Wedge Grips...page 28

Model	Type	Compatible Grip(s)	Profile	Dimensions	Temperature Range	Specimen Range	Force Capacity
AWG504.01	Flat Wedge	Advantage 10, 30, 50	Serrated Steel	50 mm x 25 mm	-130° C (-200° F) to 315° C (600° F)	0- 7.9 mm	50 kN
AWG504.02	Flat Wedge	Advantage 10, 30, 50	Serrated Steel	50 mm x 25 mm	-130° C (-200° F) to 315° C (600° F)	6- 13.2 mm	50 kN
AWG504.03	Vee Wedge	Advantage 10, 30, 50	Serrated Steel	50 mm x 25 mm	-130° C (-200° F) to 315° C (600° F)	3- 7.9 mm	50 kN
AWG504.04	Vee Wedge	Advantage 10, 30, 50	Serrated Steel	50 mm x 25 mm	-130° C (-200° F) to 315° C (600° F)	7- 12.7 mm	50 kN
AWG504.05	Vee Wedge	Advantage 10, 30, 50	Serrated Steel	50 mm x 25 mm	-130° C (-200° F) to 315° C (600° F)	11.5- 16 mm	50 kN
AWG305.01	Flat Wedge	Advantage 100, 150, 300	Serrated Steel	50 mm x 50 mm	-130° C (-200° F) to 315° C (600° F)	0- 9 mm	300 kN
AWG305.02	Flat Wedge	Advantage 100, 150, 300	Serrated Steel	50 mm x 50 mm	-130° C (-200° F) to 315° C (600° F)	6.4- 16 mm	300 kN
AWG305.03	Vee Wedge	Advantage 100, 150, 300	Serrated Steel	50 mm x 50 mm	-130° C (-200° F) to 315° C (600° F)	5- 12.5 mm	300 kN
AWG305.04	Vee Wedge	Advantage 100, 150, 300	Serrated Steel	50 mm x 50 mm	-130° C (-200° F) to 315° C (600° F)	12.2- 19.5 mm	300 kN
AWG305.05	Vee Wedge	Advantage 100, 150, 300	Serrated Steel	50 mm x 50 mm	-130° C (-200° F) to 315° C (600° F)	3.2- 7.6 mm	300 kN

WEDGES FOR MODEL 647 HYDRAULIC WEDGE GRIPS

» See Model 647 Hydraulic Wedge Grips...page 29

Model	Type	Compatible Grip(s)	Profile	Dimensions	Temperature Range	Specimen Range	Force Capacity
647.10A.01	Flat Wedge	647.10A	Diamond Tip	63 mm x 50 mm	-40° to 177° C (-40° to 350° F)	0- 7.6 mm	120 kN
647.10A.02	Flat Wedge	647.10A	Diamond Tip	63 mm x 50 mm	-40° to 177° C (-40° to 350° F)	11.7- 19.1 mm	120 kN
647.10A.03	Vee Wedge	647.10A	Serrated Steel	63 mm x 50 mm	-40° to 177° C (-40° to 350° F)	5.8 - 10.2/11.9 mm	120 kN
647.10A.04	Vee Wedge	647.10A	Serrated Steel	63 mm x 50 mm	-40° to 177° C (-40° to 350° F)	10.9 - 12.7/16.5 mm	120 kN
647.02B.01	Flat Wedge	647.02B	Sawtooth	25 mm x 38 mm	-40° to 177° C (-40° to 350° F)	0- 7.2 mm	31 kN
647.02B.02	Flat Wedge	647.02B	Sawtooth	25 mm x 38 mm	-40° to 177° C (-40° to 350° F)	7.2-14.4 mm	31 kN
647.02B.03	Flat Wedge	647.02B	Sawtooth	25 mm x 38 mm	-40° to 177° C (-40° to 350° F)	13.4-20.5 mm	31 kN
647.02B.04	Flat Wedge	647.02B	Sawtooth	25 mm x 38 mm	-40° to 177° C (-40° to 350° F)	18.8-25.9 mm	31 kN
647.02B.05	Vee Wedge	647.02B	Diamond Tip	25 mm x 38 mm	-40° to 177° C (-40° to 350° F)	3.0 - 8.1/ 9.4 mm	31 kN
647.02B.06	Vee Wedge	647.02B	Diamond Tip	25 mm x 38 mm	-40° to 177° C (-40° to 350° F)	8.9 - 10.9/15.2 mm	31 kN
647.25A.01	Flat Wedge	647.25A	Diamond Tip	50.8 x 88.9 mm (2 x 3.5 in)	-40° to 177° C (-40° to 350° F)	1.02 to 11.9 mm	333 kN
647.25A.02	Flat Wedge	647.25A	Diamond Tip	50.8 x 88.9 mm (2 x 3.5 in)	-40° to 177° C (-40° to 350° F)	6.10 to 17.0 mm	333 kN
647.25A.03	Flat Wedge	647.25A	Diamond Tip	50.8 x 88.9 mm (2 x 3.5 in)	-40° to 177° C (-40° to 350° F)	15.0 to 25.9 mm	333 kN
647.25A.04	Vee Wedge	647.25A	Serrated Steel	50.8 x 88.9 mm (2 x 3.5 in)	-40° to 177° C (-40° to 350° F)	6.4 to 13.5 mm	333 kN
647.25A.05	Vee Wedge	647.25A	Serrated Steel	50.8 x 88.9 mm (2 x 3.5 in)	-40° to 177° C (-40° to 350° F)	10.7 to 19.84 mm	333 kN
647.25A.06	Vee Wedge	647.25A	Serrated Steel	50.8 x 88.9 mm (2 x 3.5 in)	-40° to 177° C (-40° to 350° F)	16.8 to 26.2 mm	333 kN

Tensile Grips for Series 40 (EM) Systems

INSERTS FOR MTS FUNDAMENTAL NUT/BOLT/SHOULDER GRIPS

» See *MTS Fundamental Nut/Bolt/Shoulder Grips for Series 40 Systems...* page 22

Model	Type	Compatible Grip(s)	Temperature Range	Specimen Range	Force Capacity
FLA105B.01	Bolt	FLA105B	0° C (32° F) to 50° C (122° F)	M4	100 k N
FLA105B.02	Bolt	FLA105B	0° C (32° F) to 50° C (122° F)	M5	100 kN
FLA105B.03	Bolt	FLA105B	0° C (32° F) to 50° C (122° F)	M6	100 kN
FLA105B.04	Bolt	FLA105B	0° C (32° F) to 50° C (122° F)	M8	100 kN
FLA105B.05	Bolt	FLA105B	0° C (32° F) to 50° C (122° F)	M10	100 kN
FLA105B.06	Bolt	FLA105B	0° C (32° F) to 50° C (122° F)	M12	100 kN
FLA105B.07	Nut	FLA105B	0° C (32° F) to 50° C (122° F)	M4	100 kN
FLA105B.08	Nut	FLA105B	0° C (32° F) to 50° C (122° F)	M5	100 kN
FLA105B.09	Nut	FLA105B	0° C (32° F) to 50° C (122° F)	M6	100 kN
FLA105B.10	Nut	FLA105B	0° C (32° F) to 50° C (122° F)	M8	100 kN
FLA105B.11	Nut	FLA105B	0° C (32° F) to 50° C (122° F)	M10	100 kN
FLA105B.12	Nut	FLA105B	0° C (32° F) to 50° C (122° F)	M12	100 kN
FTA105B.01	Shoulder	FTA105B	0° C (32° F) to 50° C (122° F)	φ3 mm	100 kN
FTA105B.02	Shoulder	FTA105B	0° C (32° F) to 50° C (122° F)	φ5 mm	100 kN
FTA105B.03	Shoulder	FTA105B	0° C (32° F) to 50° C (122° F)	φ6 mm	100 kN
FTA105B.04	Shoulder	FTA105B	0° C (32° F) to 50° C (122° F)	φ8 mm	100 kN
FTA105B.05	Shoulder	FTA105B	0° C (32° F) to 50° C (122° F)	φ10 mm	100 kN

Compression Platens for Series 40 (EM) Systems

MTS Fundamental Steel Compression Platens

- » Value-priced, steel platens for compression testing of foam, composites, bottles, and plastic containers
- » Available in a variety of diameters with force ratings of 20 kN, 100 kN and 300 kN
- » Precision-ground, hardened surfaces enhance platen durability
- » Specimen centering grooves, anti-rotation features and integrated alignment pins enhance test accuracy and repeatability



Model	Type	Force Rating	Weight	Specimen Range	Compatible Frames	Temperature Rating	Attachment Type	Platen Height/Width
FYA204A	Steel Platen	20 kN	0.149 kg	ϕ100 mm	C42.503 C43.104 C43.304 C43.504 C44.104 C44.304 C45.504 C45.105	-50° C (-58° F) to 150° C (302° F)	D	Height 63 mm (2.480 in) Diameter 100 mm (3.937 in)
FYA105A	Steel Platen	100 kN	2.434 kg	ϕ100 mm	C43.104 C43.304 C43.504 C44.104 C44.304 C45.504 C45.105	-50° C (-58° F) to 150° C (302° F)	D	Height 86 mm (3.386 in) Diameter 100 mm (3.937 in)
FYA305A	Steel Platen	300 kN	4.2 kg	ϕ100 mm	C45.305	-50° C (-58° F) to 150° C (302° F)	E	Height 98 mm (3.86 in) WIDTH 100 mm (3.94 in)
FYB204A	Steel Platen	20 kN	3.433 kg	ϕ150 mm	C42.503 C43.104 C43.304 C43.504 C44.104 C44.304 C45.504 C45.105	-50° C (-58° F) to 150° C (302° F)	D	Height 81 mm (3.386 in) Diameter 150 mm (5.906 in)

Compression Platens for Series 40 (EM) Systems

MTS Fundamental Steel Compression Platens...continued

Model	Type	Force Rating	Weight	Specimen Range	Compatible Frames	Temperature Rating	Attachment Type	Platen Height/Width
FYB105A	Steel Platen	100 kN	4.181 kg	φ150 mm	C43.104	-50° C (-58° F) to 150° C (302° F)	D	Height 86 mm (3.386 in)
					C43.304			
					C43.504			
					C44.104			
					C44.304			
					C45.504			
C45.105	Diameter 100 mm (3.937 in)							
FYB305A	Steel Platen	300 kN	8.9 kg	φ150 mm	C45.305	-50° C (-58° F) to 150° C (302° F)	E	Height 125 mm (4.92 in)
								Diameter 150 mm 5.91 in)
FYC204A	Steel Platen	20 kN	5.305 kg	φ200 mm	C42.503	-50° C (-58° F) to 150° C (302° F)	D	Height 81 mm (3.189 in)
					C43.104			
					C43.304			
					C43.504			
					C44.104			
					C44.304			
C45.504	Diameter 200 mm (7.874 in)							
C45.105								
FYC105A	Steel Platen	100 kN	6.637 kg	φ200 mm	C43.104	-50° C (-58° F) to 150° C (302° F)	D	Height 86 mm (3.386 in)
					C43.304			
					C43.504			
					C44.104			
					C44.304			
					C45.504			
C45.105	Diameter 200 mm (7.874 in)							
FYC305A	Steel Platen	300 kN	12 kg	φ200 mm	C45.305	-50° C (-58° F) to 150° C (302° F)	E	Height 125 mm (4.92 in)
								Diameter 200 mm (7.87 in)
FYD204A	Stainless Steel Platen	20 kN	1.501 kg	φ100 mm	C44.104	-70° C (-94° F) to 350° C (662° F)	D	Height 63 mm (2.480 in)
					C44.304			
					C45.504			
					C45.105			
FYD105A	Stainless Steel Platen	100 kN	5.03 kg	φ150 mm	C43.104	0° C (32° F) to 50° C (122° F)	D	Height 100 mm (3.94 in)
					C43.304			
					C43.504			
					C44.104			
					C44.304			
					C45.504			
C45.105	Diameter 150 mm (5.91 in)							

Compression Platens for Series 40 (EM) Systems

MTS Fundamental Aluminum Compression Platens

- » Value-priced, lightweight aluminum platens for compression testing of polystyrene, rubber, composites and sintered materials and components
- » Designed for accurate testing with small load cells (1 kN and less)
- » Available in a variety of diameters with force ratings of .5 kN
- » Specimen centering grooves, anti-rotation features and integrated alignment pins enhance test accuracy and repeatability



Model	Type	Force Rating	Weight	Specimen Range	Compatible Frames	Temperature Rating	Attachment Type	Platen Height/Width	
FYA502A	Aluminum Platen	0.5 kN	0.280 kg	φ50 mm	C42.503	-50° C (-58° F) to 100° C (212° F)	D	Height 63 mm (2.480 in)	
					C43.104				
					C43.304				
					C43.504				
					C44.104				
					C44.304				
					C45.504				
C45.105	Diameter 50 mm (1.969 in)								
FYB502A		Aluminum Platen	0.5 kN	0.548 kg	φ100 mm	C42.503	-50° C (-58° F) to 100° C (212° F)	D	Height 63 mm (2.480 in)
						C43.104			
						C43.304			
						C43.504			
						C44.104			
						C44.304			
	C45.504								
C45.105	Diameter 100 mm (3.937 in)								
FYC502A		Aluminum Platen	0.5 kN	0.966 kg	φ150 mm	C42.503	-50° C (-58° F) to 100° C (212° F)	D	Height 63 mm (2.480 in)
						C43.104			
						C43.304			
						C43.504			
						C44.104			
						C44.304			
	C45.504								
C45.105	Diameter 150 mm (5.906 in)								

Compression Platens for Series 40 (EM) Systems

Bionix Stainless Steel Compression Platens

- » Value-priced, stainless steel platens suitable for compression tests of irregular biomaterials, bone, cartilage, tendons and replacement biomedical components in fluid bath environments
- » Precision-ground, hardened surfaces enhance platen durability
- » Available in a variety of diameters with force ratings of 10 kN
- » Specimen centering grooves, anti-rotation features and integrated alignment pins enhance test accuracy and repeatability
- » See *Fluid Baths for Series 40 (EM) Systems...page 51*



EnviroBath
Optional Grip.02

Model	Type	Force Rating	Weight	Maximum Specimen Diameter	Compatible Frames	Temperature Rating	Attachment Type	Height (each from clevis center)
EnviroBath Optional Grip.02	Stainless Steel Platen	10 kN	681 g	φ50 mm	C42.503	- 130° C to 250° C	D	64 mm
					C43.104			
					C43.304			
					C43.504			
					C44.104			
					C44.304			
					C45.504			
C45.105								
EnviroBath Optional Grip.03	Stainless Steel Platen	10 kN	1820 g	φ100 mm	C42.503	- 130° C to 250° C	D	64 mm
					C43.104			
					C43.304			
					C43.504			
					C44.104			
					C44.304			
					C45.504			
C45.105								
EnviroBath Optional Grip.04	Stainless Steel Platen	10 kN	3725 g	φ150 mm	C42.503	- 130° C to 250° C	D	64 mm
					C43.104			
					C43.304			
					C43.504			
					C44.104			
					C44.304			
					C45.504			
C45.105								

Compression Platens for Series 40 (EM) Systems

Model 643 Compression Platens

- » Manufactured from case-hardened steel with hard chrome plating
- » Feature spherical seats on upper grips and etched concentric rings to ensure test accuracy and repeatability
- » Available in a variety of geometries with force rating of 100 kN



Compression Platen

Model	Type	Force Rating	Weight	Specimen Range	Compatible Frames	Temperature Rating	Attachment Type	Platen Height/ Diameter
643.06A-01/-02	Steel Platen	100 kN	1.4 kg (3.2 lb)	5-58 mm	C44.104 C44.304 C45.504 C45.105 C45.305	-129° C to 177° C (-200° F to 350° F)	D	63.5 mm (2.5 in)/ 58.4 mm (2.3 in)
643.06A-03/-04	Steel Platen	100 kN	0.8 kg (1.8 lb)	5-58 mm	C44.104 C44.304 C45.504 C45.105 C45.305	-129° C to 177° C (-200° F to 350° F)	D	36.8 mm (1.45 in)/ 58.4 mm (2.3 in)
643.10A-01/-02	Steel Platen	100 kN	3.9 kg (8.6 lb)	5-102 mm	C44.104 C44.304 C45.504 C45.105 C45.305	-129° C to 177° C (-200° F to 350° F)	D	82.8 mm (3.26 in)/ 101.6 mm (4 in)
643.10A-03/-04	Steel Platen	100 kN	3.1 kg (6.8 lb)	5-102 mm	C44.104 C44.304 C45.504 C45.105 C45.305	-129° C to 177° C (-200° F to 350° F)	D	53.8 mm (2.12 in)/ 101.6 mm (4 in)
643.15A-01/-02	Steel Platen	100 kN	11.5 kg (25.4 lb)	5-152 mm	C44.104 C44.304 C45.504 C45.105 C45.305	-129° C to 177° C (-200° F to 350° F)	D	115.1 mm (4.53 in)/ 152.4 mm (6 in)
643.15A-03/-04	Steel Platen	100 kN	3.8 kg (8.4 lb)	5-152 mm	C44.104 C44.304 C45.504 C45.105 C45.305	-129° C to 177° C (-200° F to 350° F)	D	57.2 mm (2.25 in)/ 152.4 mm (6 in)
643.20A-01/-02	Steel Platen	100 kN	4.5 kg (10.0 lb)	5-203 mm	C44.104 C44.304 C45.504 C45.105 C45.305	-129° C to 177° C (-200° F to 350° F)	D	151.1 mm (5.95 in)/ 203.2 mm (8 in)
643.20A-03/-04	Steel Platen	100 kN	3.8 kg (8.4 lb)	5-203 mm	C44.104 C44.304 C45.504 C45.105 C45.305	-129° C to 177° C (-200° F to 350° F)	D	69.9 mm (2.75 in)/ 203.2 mm (8 in)
643.30A-01/-02	Steel Platen	100 kN	92.5 kg (203.9 lb)	5-305 mm	C44.104 C44.304 C45.504 C45.105 C45.305	-129° C to 177° C (-200° F to 350° F)	D	215.9 mm (8.5 in)/ 304.8 mm (12 in)
643.30A-03/-04	Steel Platen	100 kN	61.6 kg (135.9 lb)	5-305 mm	C44.104 C44.304 C45.504 C45.105	-129° C to 177° C (-200° F to 350° F)	D	101.6 mm (4 in)/ 304.8 mm (12 in)

Bend Fixtures for Series 40 (EM) Systems

MTS Fundamental 3-Point Bend Fixtures

- » Value-priced fixtures for a wide range of flexural (bend) tests on metals composites, plastics and other materials
- » Available in a range sizes with force capacities of 10 kN, 100 kN and 300 kN
- » Flexible configurations provide either a region of constant stress or a line of maximum stress
- » Precision machined rollers are made from corrosion-resistant hardened steel
- » Adjustable spans feature metric scales



Model	Type	Force Rating	Specimen Width	Upper Roller Diameter (Loading Nose Radius)	Lower Roller Diameter (Support Rod Radius)	Support Span	Compatible Frames	Temperature Rating
FWA104A	3 Point Flexure	10 kN	40 mm	5, 2 mm	5 mm, 2 mm	40-160 mm	C42.503 C43.104 C43.304 C43.504 C44.104 C44.304 C45.504 C45.105	-50° C (-58° F) to 150° C (302° F)
FWA105A	3 Point Flexure	100 kN	80 mm	10 mm	10 mm	30-360 mm	C42.503 C43.104 C43.304 C43.504 C44.104 C44.304 C45.504 C45.105	-50° C (-58° F) to 150° C (302° F)
FWA305A	3 Point Flexure	300 kN	90 mm	15 mm	15 mm	30-340 mm	C45.305	-50° C (-58° F) to 150° C (302° F)
FWB104A	3 Point Flexure	10 kN	40 mm	5, 2 mm	5 mm, 2 mm	40-160 mm	C42.503 C43.104 C43.304 C43.504 C44.104 C44.304 C45.504 C45.105	-70° C (-94° F) to 350° C (662° F)

Bend Fixtures for Series 40 (EM) Systems

Model 642 Three & Four-Point Bend Fixtures

- » Modular design accommodates 3 and 4-point configurations for a wide range of flexural (bend) testing of metals, composites, plastics and other materials
- » Available in a range sizes with force capacities of 2.89, 10 and 100 kN
- » Flexible configurations provide either a region of constant stress or a line of maximum stress
- » Precision machined rollers are made from corrosion-resistant hardened steel
- » Adjustable spans feature English and metric scales
- » See *EM Bend Fixture Rollers...* page 46



642.001A-02



642.01-02



642.10A-02

Model	Type	Force Rating	Specimen Width	Upper Roller Diameter (Loading Nose Radius)	Lower Roller Diameter (Support Rod Radius)	Support Span	Compatible Frames	Temperature Rating
642.001A-02	3 & 4 Point Flexure	2.89 kN	25 mm	1, 2, 3, 4, 5 mm	1, 2, 3, 4, 5 mm	14-60 mm	C42.503 C43.104 C43.304 C43.504 C44.104 C44.304 C45.504 C45.105	-129° C (-200° F) to 150° C (300° F)
642.01-02	3 & 4 Point Flexure	10 kN	50 mm	See EM Bend Fixture Rollers	See EM Bend Fixture Rollers	24-152 mm	C42.503 C43.104 C43.304 C43.504 C44.104 C44.304 C45.504 C45.105	-129° C (-200° F) to 150° C (300° F)
642.10A-02	3 & 4 Point Flexure	100 kN	75 mm	See EM Bend Fixture Rollers	See EM Bend Fixture Rollers	38-305 mm	C42.503 C43.104 C43.304 C43.504 C44.104 C44.304 C45.504 C45.105	-129° C (-200° F) to 177° C (350° F)
642.25B-02	3 & 4 Point Flexure	300 kN	127 mm	See EM Bend Fixture Rollers	See EM Bend Fixture Rollers	79-610 mm	C45.305	-129° C (-200° F) to 177° C (350° F)

Bend Fixtures for Series 40 (EM) Systems

ROLLERS FOR MODEL 642 BEND FIXTURES

» See Model 642 Three & Four-Point Bend Fixtures...page 45

Model	Compatible Fixtures	Roller Diameter	Force Rating
642.01.01	642.01-02	φ5 mm	10 kN
642.01.02	642.01-02	φ10 mm	10 kN
642.01.03	642.01-02	φ25 in	10 kN
642.01.04	642.01-02	φ.5 in	10 kN
642.10.01	642.10A-02	φ5 mm	100 kN
642.10.02	642.10A-02	φ10 mm	100 kN
642.10.03	642.10A-02	φ15 mm	100 kN
642.10.04	642.10A-02	φ20 mm	100 kN
642.10.05	642.10A-02	φ25 mm	100 kN
642.10.06	642.10A-02	φ.25 in	100 kN
642.10.07	642.10A-02	φ.375 in	100 kN
642.10.08	642.10A-02	φ.5 in	100 kN
642.10.09	642.10A-02	φ.75 in	100 kN
642.10.10	642.10A-02	φ1 in	100 kN
642.25.01	642.25B-02	φ20 mm	300 kN
642.25.02	642.25B-02	φ30 mm	300 kN
642.25.03	642.25B-02	φ40 mm	300 kN
642.25.04	642.25B-02	φ50 mm	300 kN
642.25.05	642.25B-02	φ0.75 in	300 kN
642.25.06	642.25B-02	φ1.00 in	300 kN
642.25.07	642.25B-02	φ1.25 in	300 kN
642.25.08	642.25B-02	φ1.50 in	300 kN
642.25.09	642.25B-02	φ1.75 in	300 kN
642.25.10	642.25B-02	φ2.00 in	300 kN

MTS Fundamental Universal Joint

» Anti-rotation features and integrated alignment pins enhance test accuracy and repeatability



Universal Joint

Model	Type	Force Capacity	Weight	Compatible Frames	Temperature Rating	Attachment Type	Grip Height/ Diameter
FWX105	Universal Joint	100 kN	4 kg (8.8 lb)	All	0° C (32° F) to 50° C (122° F)	D	139 mm (5.5 in)/ φ84 mm (3.4 in)

Environmental Simulation Tools

Model 653 Furnaces for Series 40 (EM) Systems

- » Enables testing from 100° C to 1400° C with single or multiple-zone heating
- » Ideal for high-temperature tension, compression and bend testing of metals, composites and ceramics
- » Well-suited for high-temperature tests requiring lower thermal gradient
- » Control zones with multiple heating elements facilitate precise control of temperatures and heated areas
- » Center-split design simplifies specimen and fixture access
- » *See Pull Rods for Model 653 Furnaces...page 47*
- » *See Controllers for Model 653 Furnaces...page 48*



Model 653 Furnace

Model	Temperature Range	Heating Levels	Hot Zone Dimensions (W x D x H)	Overall Height	Compatible Frames
653.01	100 to 1400° C	1	50.0 mm; 50.0 mm; 19.0 mm	55.0 mm	C44.104/104E C44.304/304E C45.504/504E C45.105/105E C45.305/305E
653.02	100 to 1400° C	2	50.0 mm; 50.0 mm; 50.0 mm	85.0 mm	C44.104/104E C44.304/304E C45.504/504E C45.105/105E C45.305/305E
653.03	100 to 1400° C	2	62.5 mm; 62.5 mm; 90.0 mm	126.0 mm	C44.104/104E C44.304/304E C45.504/504E C45.105/105E C45.305/305E
653.04	100 to 1400° C	3	62.5 mm; 62.5 mm; 185.0 mm	220.0 mm	C44.104/104E C44.304/304E C45.504/504E C45.105/105E C45.305/305E

PULL RODS FOR MODEL 653 FURNACES

- » *See MTS Fundamental Furnaces...page 48*

Model	Temperature Rating	Load Capacity	Rod Lengths	Specimen Adapter
FHA000	1050° C	80 kN	341 mm (x2)	M20 Thread
FHA010	1050° C	80 kN	345 mm (x2)	M24 Thread
FHA110	1050° C	80 kN	108 mm (x2)	M16 Thread
FHA120	1050° C	80 kN	126 mm (x2)	M12 Thread
FHA210	1050° C	80 kN	96 mm (x2)	1-4 mm Flat
FHA220	1050° C	80 kN	96 mm (x2)	4-8 mm Flat

Environmental Simulation Tools

CONTROLLERS FOR MODEL 653 FURNACES

» See *Model 653 Furnaces for Series 40 (EM) Systems...page 47*

Model	Type	Temperature Rating	Voltage
409.83-01	Single-zone controller	1400° C	230 V
409.83-02	Dual-zone controller	1400° C	230 V
409.83-03	3-zone controller	1400° C	230 V
409.83.01	Controller stand	–	–
409.83.02	Furnace/extensometer mounting stand	–	–
409.83.03	Furnace/ extensometer protective case	–	–

MTS Fundamental Furnaces

- » Value-priced furnace for testing from 300° C to 1050° C with single -zone heating
- » Ideal for high-temperature tension and compression
- » Center-split, clam shell design simplifies specimen and fixture access
- » See *Furnace Options*



MTS Fundamental Furnace

Model	Temperature Rating	Compatible Frames	Heating Zones	Hot Zone Dimensions (φ x H)	Overall Height
FGW900	300-1050° C	C45.504/504E C45.105/105E C45.305/305E	1	108 mm x 300 mm	420 mm

Environmental Simulation Tools

Advantage Environmental Chambers for Series 40 Systems

- » Increase range of temperatures available for materials testing, enabling testing at controlled temperatures from -129° C to 315° C
- » Ideal for research, quality control and production testing of elastomeric components, tire cords, plastics, composites, laminates, etc.
- » Enable testing at a constant temperature with very little gradient across the specimen
- » Compatible with video or laser extensometers
- » *See Extensions Rods for Advantage Environmental Chambers...page 50*



AEC Tall

Model	Temperature Rating	Compatible Frames	Internal Dimensions (W x D x H)	External Dimensions (W x D x H)	Cooling Mechanism	U-Plug (Y/N)
AEC 10x10x24	-129 to 315° C	C43.104/104E	254 mm	400 mm	LN2	Y
		C43.304/304E	254 mm	711 mm		
		C43.504/504E	610 mm	864 mm		
		C44.104/104E				
		C44.304/304E				
AEC 14x17x24	-129 to 315° C	C45.504/504E	356 mm	533 mm	LN2	Y
		C45.105/105E	432 mm	889 mm		
		C45.305/305E	610 mm	864 mm		
AEC 10x10x32	-129 to 315° C	C43.104E	254 mm	400 mm	LN2	Y
		C43.304E	254 mm	711 mm		
		C43.504E	813 mm	1067 mm		
		C44.104E				
		C44.304E				
AEC 14x17x32	-129 to 315° C	C45.504E	356 mm	533 mm	LN2	Y
		C45.105E	432 mm	889 mm		
		C45.305E	813 mm	1067 mm		

Environmental Simulation Tools

EXTENSION RODS FOR ADVANTAGE ENVIRONMENTAL CHAMBERS

» See *MTS Fundamental Environmental Chambers...page 50*

Model	Temperature Rating	Load Capacity	Lengths
Type C	-130 to 315° C (-200 to 600° F)	.2 kN	250 mm (9.8 in) 200 mm (7.8 in) 150 mm (5.9 in) 125 mm (4.9 in) 125 mm (4.9 in) 100 mm (3.9 in)
Type D	-130 to 315° C (-200 to 600° F)	150 kN	250 mm (9.8 in) 200 mm (7.8 in) 150 mm (5.9 in) 125 mm (4.9 in) 100 mm (3.9 in)
F007003	-70 to 350° C	100 kN	100 mm (3.9 in) 125 mm (4.9 in) 150 mm (5.9 in) 200 mm (7.8 in) 250 mm (9.8 in) 300 mm (11.7 in)

MTS Fundamental Environmental Chambers

- » Value-priced chamber for enabling testing at controlled temperatures from -70° C to 350° C
- » Ideal for research, quality control and production testing of elastomeric components, tire cords, plastics, composites, laminates, etc.
- » Compatible with video or laser extensometers



MTS Fundamental Environmental Chambers

Model	Temperature Rating	Compatible Frames	Internal Dimensions (W x D x H)	External Dimensions (W x D x H)	Cooling Mechanism	U-Plug (Y/N)
FEC 1200	-70 to 350° C (-94 to 662° F)	C43.104/104E C43.304/304E C44.104/104E C44.304/304E	200 x 195 x 600 mm	360 x 1055 x 848 mm	LN2	Y
FEC 1300	-70 to 350° C (-94 to 662° F)	C45.504/504E C45.105/105E C45.305/305E	300 x 250 x 600 mm	460 x 1055 x 853 mm	LN2	Y

Environmental Simulation Tools

Fluid Baths for Series 40 (EM) Systems

- » Enables mechanical testing of medical device and biomaterial specimens in fluids heated to body temperatures
 - » Available in 1, 6 and 10 liter volumes
 - » Supports saline and protein-based fluids
 - » Highly reliable temperature control system
 - » Compatible with video or laser extensometers
 - » Leak-proof access panels enable easy change out of accessories and specimens
 - » Easy disassembly simplifies cleaning and regular maintenance
- » *See Fluid Bath Options...page 51*
 - » *See Bionix Bollard Grips...page 22*
 - » *See Bionix Roller Grips...page 23*
 - » *See Bionix Scissors Grips...page 24*
 - » *See Bionix Vise Grips...page 25*
 - » *See Bionix Stainless Steel Compression Platens...page 42*



Bionix EnviroBath 1

Model	Volume	Compatible Frames	Internal Dimensions (H x W x D)	External Dimensions (H x W x D)	Temperature Rating
Bionix EnviroBath 1	1 liter	C42.503/503E	200 mm;	295 mm;	5° C above ambient to 40° C
		C43.104/104E	100 mm;	180 mm;	
		C43.304/304E	56 mm	95 mm	
		C43.504/504E			
		C44.104/104E			
		C44.304/304E			
		C45.504/504E			
Bionix EnviroBath 6	6 liter	C42.503E	480 mm;	575 mm;	5° C above ambient to 40° C
		C43.104/104E	130 mm;	205 mm;	
		C43.304/304E	100 mm	140 mm	
		C43.504/504E			
		C44.104/104E			
		C44.304/304E			
		C45.504/504E			
Bionix EnviroBath 10	10 liter	C42.503E	305 mm;	395 mm;	5° C above ambient to 40° C
		C43.104/104E	215 mm;	295 mm;	
		C43.304/304E	150 mm	190 mm	
		C43.504/504E			
		C44.104/104E			
		C44.304/304E			
		C45.504/504E			

FLUID BATH OPTIONS:

Model	Type
EnviroBath Controller	EnviroBath 1 Circulator (240 V AC)
EnviroBath Controller	EnviroBath 6 and 10 Circulator (240 V AC)
EnviroBath Controller	EnviroBath miscellaneous required tubing and fittings
EnviroBath Option	EnviroBath 1 Lid
EnviroBath Option	EnviroBath 6 and 10 Lid
EnviroBath Option	230 V European - Schuko Plug
EnviroBath Option	230 V European - Locking Plug
EnviroBath Option	EnviroBath 6 Spray
EnviroBath Option	EnviroBath 10 Spray
EnviroBath Option	EnviroBath 1 - Protein Fluid Serum Distribution Assembly
EnviroBath Option	EnviroBath 6 and 10 - Protein Fluid Serum Distribution Assembly

Spares Kits

Model	Description	Compatible Frames
C42.503	This kit includes certain switches, bellows, all belts, clevis pins and tools.	C42.503/503E
C43.104	This kit includes certain switches, bellows, all belts, clevis pins and tools.	C43.104/104E
C43.304	This kit includes certain switches, bellows, all belts, clevis pins and tools.	C43.304/304E
C43.504	This kit includes certain switches, bellows, all belts, clevis pins and tools.	C43.504/504E
C44.104	This kit includes certain switches, bellows, all belts, clevis pins and tools.	C44.104/104E
C44.304	This kit includes certain switches, bellows, all belts, clevis pins and tools.	C44.304/304E
C45.504	This kit includes certain switches, bellows, all belts, clevis pins and tools.	C45.504/504E
C45.105	This kit includes certain switches, bellows, all belts, clevis pins and tools.	C45.105/105E
C45.305	This kit includes certain switches, bellows, all belts, clevis pins and tools.	C45.305/305E

Regional Business Centers

THE AMERICAS

MTS Systems

14000 Technology Drive
Eden Prairie, MN 55344-2290

USA

Telephone: 952-937-4000
Toll Free: 800-328-2255
E-mail: info@mts.com
Internet: www.mts.com

EUROPE

MTS Systems France

BAT EXA 16
16/18 rue Eugène Dupuis
94046 Créteil Cedex

France

Telephone: +33-(0)1-58 43 90 00
E-mail: contact.france@mts.com

MTS Systems (Germany) GmbH

Hohentwielsteig 3
14163 Berlin

Germany

Telephone: +49-(0)30 81002-0
E-mail: euroinfo@mts.com

MTS Systems S.R.L. a socio unico

Strada Pianezza 289
10151 Torino

Italy

Telephone: +39-(0)11 45175 11 sel. pass.
E-mail: mtstorino@mts.com

MTS Systems Norden AB

Datavägen 37b
SE-436 32 Askim

Sweden

Telephone: +46-(0)31-68 69 99
E-mail: norden@mts.com

MTS Systems Limited

98 Church Street,
Hunslet,

Leeds

LS102AZ

United Kingdom

Telephone: +44 (0) 113 270 8011
E-mail: mtsuksales@mts.com

ASIA/PACIFIC

MTS Japan Ltd.

Raiden Bldg. 3F 3-22-6,
Ryogoku, Sumida-ku,
Tokyo 130- 0026

Japan

Telephone: +81 3 5638 0850
E-mail: mts-j-info@mts.com

MTS Korea, Inc.

4th F., ATEC Tower, 289,
Pankyo-ro, Bundang-gu
Seongnam-si
Gyeonggi-do 13488,

Korea

Telephone: 82-31-728-1600
E-mail: mtsk-info@mts.com

MTS Systems (China) Co., Ltd.

Floor 34, Building B,
New Caohejing International
Business Center,
No.391, Guiping Road,
Xuhui District
Shanghai 200233

P.R.China

Telephone: +021-24151000
Market: 021-24151111
Sales: 021-24151188
Service: 021-24151198
E-mail: MTSC-Info@mts.com

MTS Testing Solutions Pvt Ltd.

Unit No. 201 & 202, Second Floor
Donata Radiance,
Krishna Nagar Industrial Layout,
Koramangala, Bangalore - 560029
Karnataka, India
Telephone: + 91 80 46254100
Email: mts.india@mts.com



MTS Systems

14000 Technology Drive
Eden Prairie, MN 55344-2290 USA

ISO 9001 Certified QMS
<http://www.mts.com>

MTS and Bionix are registered trademarks and Advantage, MTS Criterion, MTS Fundamental and MTS TestSuite are trademarks of MTS Systems in the United States. These trademarks may be protected in other countries. RTM No. 211177.

©2022 MTS Systems
100-248-198h Criterion Accessories • Printed in U.S.A. • 08/22